

NON-POLARIZED (BI-POLARIZED) ALUMINUM ELECTROLYTIC CAPACITORS

M.D.L.®

B04 B04R & B04A Type Series

B04

1) Dimensions (外觀型式):

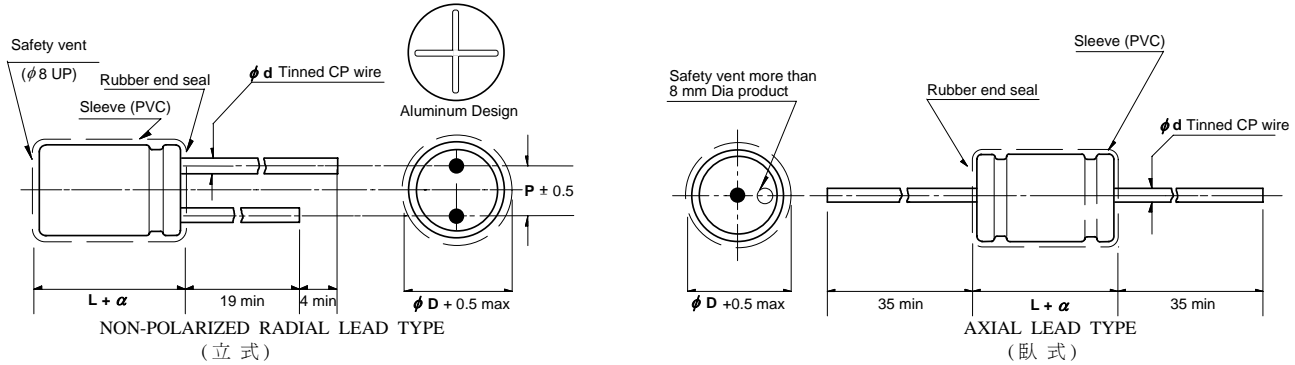

Unit (mm)

φ D	8	10	13	16	18	22
φ d	0.5	0.6	0.6	0.8	0.8	0.8
P	3.5	5.0	5.0	5.0	7.5	10
α	1.0	1.5	1.5	1.5	1.5	2.0

φ D	8	10	13	16	18	22
φ d	0.6	0.6	0.6	0.8	0.8	0.8
α	1.5	1.5	2.0	2.0	2.0	2.0

- 2) Capacitance Tolerance (容量誤差) : ±10% (K) at 1KHZ
- 3) Leakage Current (洩漏電流) : MAX. 0.03CV + 3μA After 5 minutes application of rated working voltage (MAX.0.03CV + 3μA, 印加額定電壓5分鐘後測定)
- 4) Temp Range (工作溫度範圍) : - 40°C ~ + 85°C
- 5) Load Life (壽命測試) : After 1,000 hours application of rated voltage at 85 ±2°C, capacitors meet the characteristics requirement listed at right. (以下數值是在印加額定電壓及85±2°C於1,000小時後測定)
 - (a) Capacitance change: Within ±25% of initial (電容量改變: 不超過±25%的初始值)
 - (b) Tan δ: 150% or less of initial specified (損失角: 不超過150%的初始值)
 - (c) Leakage current : Install specified value or less (洩漏電流: 不超過初期規格)
- 6) MAX Dissipation Factor (最大損失角): MAX 4% at 1KHz

B04R SERIES

B04A SERIES

RADIAL LEADS (立式)				
CAP(μF)	50 V		100 V	
	SIZE φ D*L(mm)	M.D.L. Code	SIZE φ D*L(mm)	M.D.L. Code
1	13 * 21	B04R-050K0101321	13 * 21	B04R-100K0101321
1.5	13 * 21	B04R-050K1R51321	13 * 21	B04R-100K1R51321
2.2	13 * 21	B04R-050K2R21321	13 * 21	B04R-100K2R21321
3.3	13 * 21	B04R-050K3R31321	13 * 26	B04R-100K3R31326
4.7	13 * 26	B04R-050K4R71326	13 * 26	B04R-100K4R71326
6.8	13 * 26	B04R-050K6R81326	13 * 26	B04R-100K6R81326
8.2	13 * 26	B04R-050K8R21326	13 * 26	B04R-100K8R21326
10	13 * 26	B04R-050K1001326	13 * 26	B04R-100K1001326
15	13 * 26	B04R-050K1501326	13 * 26	B04R-100K1501326
22	13 * 26	B04R-050K2201326	13 * 26	B04R-100K2201326
33	13 * 26	B04R-050K3301326	16 * 27	B04R-100K3301627
47	16 * 27	B04R-050K4701627	16 * 27	B04R-100K4701627
56	16 * 27	B04R-050K5601627	16 * 27	B04R-100K5601627
68	16 * 32	B04R-050K6801632	16 * 32	B04R-100K6801632
100	16 * 38	B04R-050K1011638	18 * 38	B04R-100K1011838

AXIAL LEADS (臥式)				
CAP(μF)	50 V		100 V	
	SIZE φ D*L(mm)	M.D.L. Code	SIZE φ D*L(mm)	M.D.L. Code
1	13 * 27	B04A-050K0101327	13 * 27	B04A-100K0101327
1.5	13 * 27	B04A-050K1R51327	13 * 27	B04A-100K1R51327
2.2	13 * 27	B04A-050K2R21327	13 * 27	B04A-100K2R21327
3.3	13 * 27	B04A-050K3R31327	13 * 32	B04A-100K3R31332
4.7	13 * 32	B04A-050K4R71332	13 * 32	B04A-100K4R71332
6.8	13 * 32	B04A-050K6R81332	13 * 32	B04A-100K6R81332
8.2	13 * 32	B04A-050K8R21332	13 * 32	B04A-100K8R21332
10	13 * 32	B04A-050K1001332	13 * 32	B04A-100K1001332
15	13 * 32	B04A-050K1501332	13 * 32	B04A-100K1501332
22	13 * 32	B04A-050K2201332	13 * 32	B04A-100K2201332
33	13 * 32	B04A-050K3301332	16 * 34	B04A-100K3301634
47	16 * 34	B04A-050K4701634	16 * 34	B04A-100K4701634
56	16 * 34	B04A-050K5601634	16 * 34	B04A-100K5601634
68	16 * 38	B04A-050K6801638	16 * 38	B04A-100K6801638
100	18 * 44	B04A-050K1011844	18*44	B04A-100K1011844

ANY SPECIAL VALUE ARE ACCEPTABLE, ITS SIZE TO BE PROVIDED UPON REQUESTED
 SIZE MAYBE CHANGED W/O NOTICE. SPECIAL SIZE IS ACCEPTABLE

- 如有需特殊尺寸 / 容量 - 請洽本公司。
- 尺寸如有更動, 不另行通知。