

Specification Approval Sheet(Cell-PCM) 产品规格确认书（电池组）

Model: CELALB401120-PCM

型号: CELALB401120-PCM

样品编号:

Customer P/N:

客户编码: 120165

批准 APPROVED BY	确认 CHECKED BY	准备 PREPARED BY
李刚	杨侠	肖太阳

客户认可

承认单位 DEPT	
确认 APPROVED BY	

备注: 本公司保留在未通知客户的情况下, 对规格书进行修改的权利!

Remark: CEL Battery may, at any time, at its sole discretion, make changes to the technical and functional specifications, the design, process, materials or other features of any of the batteries.

确认后请回传

地址: 广东省东莞市塘厦镇蛟乙塘银湖工业区金赛尔电池有限公司

Add: No.11, Yinhu Industrial Park, JiaoYiTang Village, TangXia Town, DongGuan City, GuangDong Province

Golden CEL battery co.,ltd.

电话(Tel): 86-769-82195308

传真(Fax): 86-769-87982226

网址(Web): <http://www.celbattery.com>

电子邮箱(E-mail): sales@celbattery.com

Content

目录

1. Scope -----	3
适用范围	
2. Model-----	3
编码规则	
3. Dimensions of battery pack-----	3
电池组尺寸	
4. Specifications of battery pack-----	4
电池组规格	
5. Specification of cell-----	5
电芯规格	
6. Performance Criteria and Electrical characteristics -----	5
性能检查、测试及充放电性能	
7. Mechanical characteristics-----	6
机械特性	
8. Protection Functions -----	8
保护功能	
9. Visual inspection -----	9
外观检查	
10. Standard environmental test condition -----	9
标准测试环境	
11. Pack -----	9
包装	
12. Storage-----	9
贮存	
13. Dangers-----	10-11
危险	
14. Warnings-----	11-12
警告	
15. Cautions-----	12
注意	
16. Others-----	12
其它	

1、 Scope

This document describes the Product Specification of the Lithium-Polymer (LIP) rechargeable battery cell supplied By GOLDEN CEL BATTERY (DONGGUAN) CO., LTD.

适用范围

本规格说明书描述了东莞金赛尔电池有限公司（以下简称赛尔电池）生产的可充电聚合物锂离子电池的产品性能指标

2、 Model: CELALB401120-PCM

型号：CELALB401120-PCM CEL—金赛尔电池有限公司 ALB-先进锂离子电池 PCM—保护板

3、 Dimensions of battery pack

电池组尺寸

4.0±0.2mm(T)* 11.0±0.5mm (W) * 21.0±0.3mm(H)

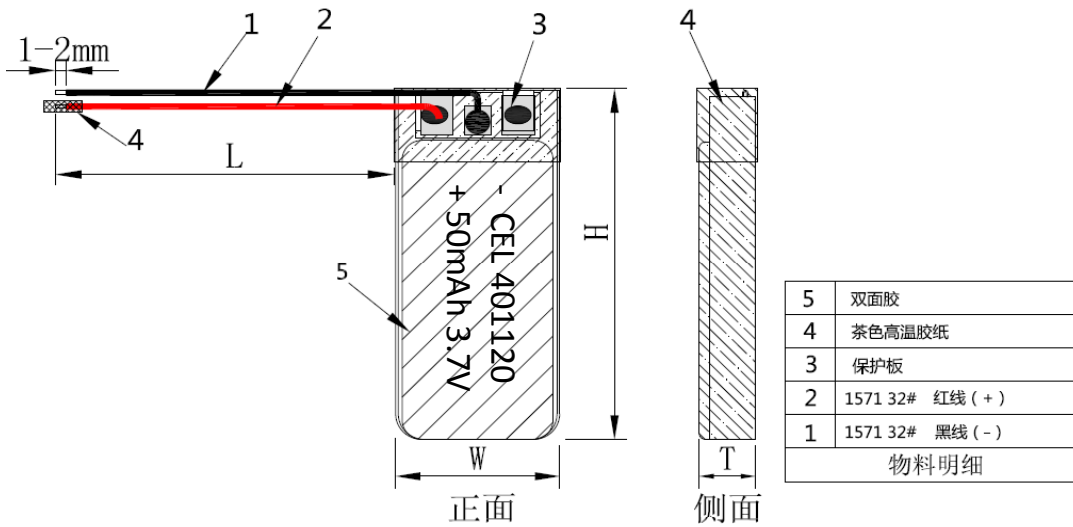

注:从电池背面、左侧、正面、右侧 环包一圈茶色高温胶

Connecting Wires (AWG32#, L=12±2mm)

接线方式

Red: connect to “+” 红色接正极

Black : connect to ground “-” 黑色接负极

4、Specifications of battery pack

电池组规格

No	Item项目	Specifications规格	Test tools测试工具	Comments备注
4.1	Nominal Capacity 标称容量	50mAh	Secondary batteries test equipment 二次电池检测设备	
4.2	Nominal voltage 标称电压	3.7V		
4.3	Dimensions (mm) 尺寸	4.0±0.2mm(T)* 11.0±0.5mm (W) * 21.0±0.3mm(H)	Calipers 数显卡尺	Exactitude 0.01mm 精确到±0.01mm
4.4	Approx. Weight (g) 参考重量	约1.4g	Electronic weighbridge 数显电子称	
4.5	Max Charge voltage 最高充电电压	4.2V	Electronic voltage meter 数字电压表	Exactitude ±0.01V 数字电压表用最少3位显示 20V以下, 精度为±0.01V
4.6	Fast Charge current 快速充电电流	0.5C mA	Secondary batteries test equipment 二次电池检测设备	
4.7	Min Discharge voltage 最低放电电压	2.75V		
4.8	Fast Discharge 快速放电电流	0.5C mA		
4.9	Charge temperature 充电温度	0°C ~ + 45°C	Thermometer 量温仪	
4.10	Discharge temperature 放电温度	-10°C ~ + 50°C		
4.11	Storage temperature 储存温度	-10°C ~ + 35°C		
4.12	Storage humidity 储存湿度	< 75%RH	Hygrometer 湿度计	

5、Specifications of cell

电芯规格

NO.	Items项目	Specifications规格	Test tools测试工具	Comments备注
5.1	Max Charge voltage 最高充电电压	4.2V	Electronic voltage meter 数字电压表	±0.01V
5.2	Min Discharge cut-off voltage 最低放电截止电压	2.75V		
5.3	Nominal capacity 标称容量	50mAh	Secondary batteries test equipment 二次电池检测设备	
5.4	AC Impedance 交流内阻	≤600mΩ	Impedance test equipment 内阻测试仪	AC 1000HZ impedance exactitude ±1 mΩ 1000HZ交流阻抗, 精确到 ±1 mΩ
5.5	Standard Charge 标准充电	0.2C CC (constant current) charge to Max Charge voltage(5.1),then CV(constant voltage 4.2V)charge till charge current decline to ≤0.01C 0.2C CC (恒流) 充电至最高充电电压(5.1), 再CV(恒压4.2V) 充电直至充电电流≤0.01C	Electronic voltage meter 数字电压表 Secondary batteries test equipment 二次电池检测设备	
5.6	Charging time 充电时间	Standard Charging: 3.5hours (Ref.) 标准充电: 3.5小时(参考值)	Secondary batteries test equipment 二次电池检测设备	
5.7	Standard discharge 标准放电	0.2C CC (constant current) discharge to Min Discharge cut-off voltage(5.2) 0.2C CC (恒流) 放电至最低放电截止电压(5.2)	Electronic voltage meter 数字电压表 Secondary batteries test equipment 二次电池检测设备	
5.8	Rapid Charge current 快速充电电流	Rapid charge: 0.5C 快速充电: 0.5C	Secondary batteries test equipment 二次电池检测设备	
5.9	Rapid discharge current 快速放电电流	0.5C		
5.10	Cell Dimension 电芯尺寸	Height 高度: 20.5mm Max (not including tabs) Width 宽度: 11.5mm Max Thickness 厚度: 4.1mm Max	Calipers 数显卡尺	Exactitude ±0.01mm 精确到±0.01mm

6、 Battery Cell Performance Criteria and Electrical characteristics

电芯性能检查、测试及充放电性能

NO.	Items项目	Test Method and Condition测试方法和环境	Test tools测试工具	Criteria标准
6.1	Rated Capacity 电池容量	discharge the cell with Standard discharge(5.7) , after Standard Charge(5.5) 该容量是指标准充电(5.5)后, 按照标准放电(5.7)所放出的容量。	Electronic voltage meter 数字电压表 Secondary batteries test	≥ Standard capacitance 95% ≥ 标称容量 95%
6.2	Cycle Life 循环寿命	the cell shall be test as Rated Capacity method(6.1), repeat 300 times 电池用测试电池容量 (6.1) 的方法,记录放电容量,重复300次.	equipment 二次电池检测设备	300 time of discharging capacities keep 80% 300次放电容量率:80%
6.3	Self-discharge 自放电	After the standard charge(5.5), storied the cells under the condition as 20±5°C for 28 days, then measured the capacity with standard discharge(5.7) 标准充电 (5.5) 后, 在20±5°C条件下贮存28天, 再以标准放电 (5.7) 方法所放出的容量。		Residual capacity: >90% 容量保持: >90%
6.4	Initial impedance of cell 电芯初始内阻	Internal resistance measured at AC 1KHz after 50% charge 半充状态下, 测量其AC 1KHz下的交流阻抗	Impedance test equipment 内阻测试仪	≤ AC Impedance (5.4) ≤ 交流内阻 (5.4)
6.5	Cell Voltage 电芯电压	As of shipment. 出货状态	Electronic voltage meter 数字电压表	3.8V~4.1V
6.6	Temperature Characteristics 温度特性	1. According to item 5.5, at 20±5°C. 2. Capacity comparison at each temperature, measured with standard discharge(5.7). Percentage as an index of the capacity compared with 100% at 20°C 1.在20±5°C条件下, 用5.5方法充电。 2.在不同温度条件下, 用5.7方法放电。以20°C时放电容量为基准计算百分比。	Electronic voltage meter 数字电压表 Secondary batteries test equipment 二次电池检测设备	-10°C: ≥60% 20°C: 100% 50°C: ≥85%

7、Mechanical characteristics

机械特性

NO.	Items项目	Test Method and Condition测试方法和环境	Test tools测试工具	Criteria 标准
7.1	Vibration Test 振动测试	After standard charge (5.5) , fixed the cell to vibration table and subjected to vibration cycling that the frequency is to be varied at the rate of 1Hz per minute between 10Hz and 55Hz, the excursion of the vibration is 1.6mm.The cell shall be vibrated for 30 minutes per axis of XYZ axes 将标准充电后的电池固定在振动台上, 沿X、Y、Z三个方向各振动30分钟, 振幅1.6mm, 振动频率为10Hz~55Hz, 每分钟变化为1Hz。	Secondary batteries test equipment、Vibration platform 二次电池检测设备、振动台	No fire不起火 No smoke不冒烟 No explosion不爆炸
7.2	Over charge 过充测试	Battery charged at 1.0C5mA current with a voltage limit of 4.8V.charging is continued for 8 hours. 标准充电后, 恒流恒压源设定为4.8V, 以1C5A的电流持续充电8h		No fire不起火 No explosion不爆炸
7.3	Over discharge 过放测试	After standard discharge (5.7) ,then connect cells terminals with 30 Ω,Discharging is continued for 24 hours 标准放电 (5.7) 后, 外接30Ω的负载放电24h		
7.4	Heating Test 热冲击测试	The temperature of the oven is to be raised at a rate of 5±2℃/min. to a temperature of 120±2℃, and remains for 30 minutes at this temperature. 电池置于热箱中、温度以 (5±2) °C/min 升到120±2℃并保温30分钟	Hot box 热箱	No fire不起火 No explosion不爆炸
7.5	Short-circuit Test 短路保护测试	The battery shall be subjected to a short-circuit condition with a wire of resistance less than 100mΩ for 1 hour. 标准充电(5.5)后, 用100mΩ电阻短路1小时	Electronic voltage meter 数字电压表、 Secondary batteries test equipment 二次电池检测设备	No fire不起火 No explosion不爆炸
7.6	High temperature and high humidity test 高温高湿测试	cell shall be charged in stored under 40℃±2℃ and 90%RH-95%RH for 48 hours. 标准充电后, 将电池放入40℃±2℃, 相对湿度为90%-95%的恒温恒湿箱中搁置48h后。	Thermometer Hygrometer 量温仪, 湿度计	Discharge time ≥ 36mins 放电时间36mins No distortion不变形, No explosion不爆炸

8、Protection Functions

保护功能

8.1 Circuit Diagram 电路原理图

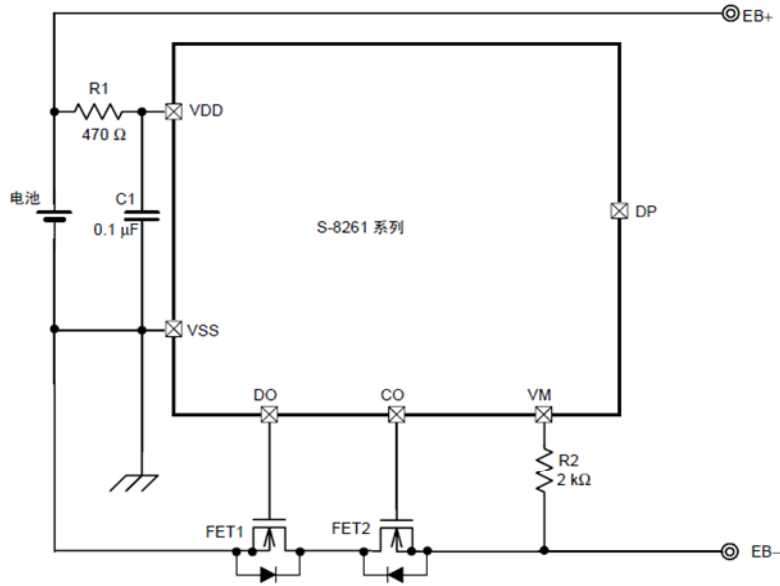

8.2 PCMA BOM

Item	Reference	Description	Type	Qty
8.2.1	U1	Protection Ic	G3J	1
8.2.2	U2	Power Mosfet	8205	1
8.2.3	R1	Resistor	470Ω ± 5%	1
8.2.4	R2	Resistor	2KΩ ± 5%	1
8.2.5	C1	Capacitor	0.1uF ± 20%	1
8.2.6	PCB	PCB	FR3 0.6 ± 0.1mm Operating Temperature -40°C ~ +85°C	1

8.3 PCM parameter PCM 参数

NO	Items	Criteria
8.3.1	Over - charge Protection voltage. 过充保护电压.	4.28 ± 0.025V
8.3.2	Over - discharge Protection voltage. 过放保护电压.	3.0 ± 0.05V
8.3.3	Over - current Protection. 过流保护.	1~2.5A
8.3.4	Current consumption in normal operation 工作时消耗电流	7uA Max

9 Visual inspection

There shall be no such defect as scratch, flaw, crack, and leakage, which may adversely affect commercial value of the cell.

外观检查

不允许有任何影响电池性能的外观缺陷，诸如裂纹、裂缝、泄漏等。

10 Standard environmental test condition

Unless otherwise specified, all tests stated in this Product Specification are conducted at below condition:

Temperature: $20 \pm 5^\circ\text{C}$

Humidity: $60 \pm 15\%RH$

Barometric: $86\text{kpa}-106\text{kpa}$

标准测试环境

除非特别说明，本标准书中所有测试均在以下环境条件下进行：

温度： $20 \pm 5^\circ\text{C}$

湿度： $60 \pm 15\%RH$

大气压： $86\text{kpa}-106\text{kpa}$

11、Pack

包装：

The sketch, size, color of marking should match GB/T191-2000 requests.

标志的图形、尺寸、颜色应符合GB/T 191 – 2000的要求

11.1 Model and specification of product;

产品的名称和型号及规格；

11.2 Quantity;

数量；

11.3 Measure up marking;

合格品标识；

11.4 Make date;

制造日期；

11.5 Other markings, like color.

其他标识，如颜色。

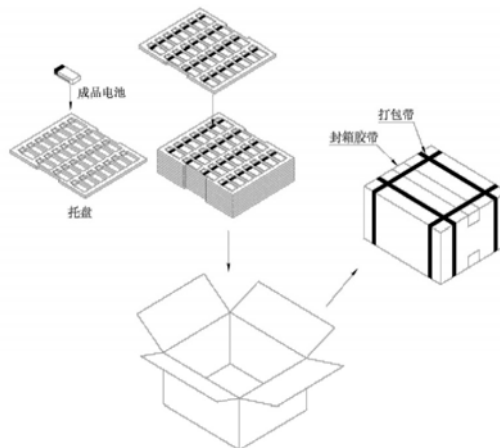

12、Storage

贮存

Long Time Storage

If the Cell is stored for a long time, the cell' s storage should be 3.8-4.1V and the cell is to be stored in a condition as No.6.6.

长期贮存

长期贮存的电池（超过3个月）须置于干燥、凉爽处。贮存电压为3.8-4.1V且贮存环境要求如6.6。

13. Dangers

危险

13.1 Don't disassemble or modify the battery.

The battery has safety function and protection circuit to avoid the danger. CEL cell is packaged by Aluminum laminated plastic film which is easy to be damaged by sharp edge such as pin, needle, edge of devices like nickel tabs, etc. If they have serious damage, electrolyte leakage, short-circuit between positive and negative tabs, etc. It would cause the generation, smoke, rupture, or flaming with mishandling.

禁止分解或修改电池。

电池装有安全保护电路避免发生危险。赛尔电池外层的铝塑膜包装很容易被锋利的东西损害，如钉、针、像定位镍片的装置等。如果电池有严重的损害，如电解液泄露，在正极片与负极片之间发生短路等，将会引起冒烟，破裂，燃烧等不正常现象。

13.2 Don't incinerate or heat the battery

Don't use or leave battery nearby fire, stove or heated place (more than 130°C). These occur the melting of insulator, damage of safety function, or ignition on electrolyte. In case that separator made of polymer is melted by high temperature, the internal short-circuit occurs in individual cells and then it would cause the generating, smoke, rupture or flaming.

禁止将电池投入火中或加热

禁止在火、火炉附近或热的地方使用(超过 130°C)。以免熔化绝缘层，损害电路保护功能，或使电解液着火，以防万一聚合物被高温熔化，使电池内发生短路，然后会引起冒烟，破裂或燃烧。

13.3 Don't use any damage battery

Don't use the battery that are dented or bent on their edge part. CEL batteries are possible to be damaged by strong mechanical shock and it would cause wire break, short-circuit inside the cell, leakage of electrolyte, etc.

禁止使用任何损坏的电池

不要使用有凹痕或被零件弯曲的电池，电池可能是被强裂的机械冲击所损害的，而且会引起电线断开，内部发生短路，电解液泄露等。

13.4 Don't drive a nail into a battery, strike it by hammer, or tread it.

As the battery might be broken or deformed and then it will be short-circuited, it would cause the generating, smoke, rupture or flaming.

禁止在电池上面钉入钉子，或锤击，踩踏电池。

当电池打折或变形时，将会发生短路，引起冒烟、破裂、燃烧。

13.5 Don't give battery impact or fling it

If the protection circuit assembled in the battery is broken, the battery will be charged at abnormal voltage or current and abnormal chemical reaction will occur. It may cause the generating, smoke, rupture or flaming.

禁止冲击或抛掷电池

如果装配在电池的保护电路被破坏，电池将会出现不正常的电压和电流和电池内部出现不正常的化学反应。它可能会引起冒烟，破裂

13.6 Don't make the direct ultrasonic wave power to the battery or soldering near the battery

It may cause serious damage to the batteries. Soldering near the battery may cause damage of the components, such as separator and insulator, are melted by heat, it would cause the gas generating, smoke, rupture or flaming.

禁止在电池上直接做超声波或电池旁边焊接

它会对电池造成严重的伤害，在电池旁边焊接可能会导致电池成分破坏，隔离层和绝缘体被热融化，会引起气体产生、冒烟、破裂或燃烧。

13.7 Don't use battery nearby the high temperature place or under the blazing sun.

CEL batteries have possibility to be degraded its performance such as capacity, thickness increase, impedance, etc. The battery will be charged at the abnormal chemical reaction occurs in the high temperature place. The thickness change may lead to stressing on battery case/ device, wiring or cell which may have possibility to lead to damage performance

禁止将电池放在高温或阳光直射的地方

在阳光下可能会使赛尔电池的寿命、性能和容量缩短，厚度增加等，在高温的地方电池内部可能会发生不正常的化学反应。厚度改变可能导致压力在电池/装置上，可能导致线路或电池性能损坏。

13.8 Don't use the unspecified charger.

If the battery is charged with unspecified condition (under high temperature over the regulated value, excessive high voltage or current over regulated value, or remodeled charger with PCM failed or disassemble), there are causes that it will be overcharged or the abnormal chemical reaction will occur in cells. It causes the gas generating, smoke, rupture or flaming.

禁止使用未经指定的充电器

如果电池与未经指定的充电器(在高温之下进行调节, 或过高的电压和电流进行调节, 或改造过的充电器用保护板保护失败或分解)会使电池充完后, 可能会导致不正常的化学反映在电池内发生, 将会产生气体、冒烟、破裂或燃烧。

13.9 Don't reverse polarity (and terminals)

If the protection circuit assembled in the battery is broken. On charging, the battery is reversed-charged and abnormal chemical reaction occurs. There may be case that unexpected large current flows on discharging. There causes the generating, smoke, rupture or flaming.

禁止将正负极接反 (和接线端)

如果电池中组合的保护线路被断掉, 在充电, 电池在接反时充电电池将发生不正常的反学反应, 那种情况有可能会产生意想不到的大电流放电。那种原因可能会使电池冒烟、破裂、燃烧。

13.10 Don't reverse-charge or reverse-connect

The battery has polarity. In case the battery is not connected with charger or equipment smoothly do not force them to connect and do check polarity of battery. If the battery is connected to opposite polarity with charger. It will be reverse-charged and abnormal chemical reaction will occur. If the protection circuit assembled in the battery is broken, it would cause the generating, swelling, smoke, rupture or flaming.

禁止将充电接反或连接接反

电池有两极, 如果电池没有平稳的与充电器或设备连接, 将不会做强制他们连接而且检查正负极与充电器是否一致, 如果电池与充电器接反, 它接会反向充电, 而且会引起发生不正常的化学反应。如果电池中装配的保护线路被断掉, 它将会引起膨胀、冒烟、破裂或燃烧。

13.11 Don't connect battery to the plug socket or car-cigarette-plug

Added high voltage to the battery, if the protection circuit assembled in the battery is broken, the excessive current will flow in it and then it may cause the generating, swelling, smoke, rupture or flaming.

禁止将电池连接到插座或汽车的点烟器

更多的高压电流流入电池, 如果装配在电池内的保护线路被断掉, 过多的电流将会产生膨胀、冒烟、破裂或燃烧。

13.12 Don't use battery for another equipment

If the battery is used for unspecified equipment, it will deteriorate its performance and cycle-life.

禁止使电池用不同的设备上

如果电池用在未指定的设备上, 它将会缩短电池的周池和寿命。

13.13 Don't touch a leaked battery directly

In case the leaked electrolyte gets into eyes, wash them with fresh water as soon as possible without rubbing eyes. And then, see a doctor immediately. If leave damaged eyes undone, it will cause eye-trouble.

禁止直接碰触漏液的电池

万一泄漏的电解液进入眼睛, 应尽快用用清水冲洗眼睛, 然后, 立刻去看医生。如果眼睛被伤害, 将会引起眼睛疾病。

14. Warnings

警告

14.1 Keep the battery away from babies

Keep the little battery out of the reach of babies in order to avoid troubles by swallowing. In case of swallowing the battery, see a doctor immediately.

电池应远离小孩

以免小孩吞下电池, 出现不必要的麻烦, 应该将电池放到小孩接触不到的地方。如果吞下电池, 请立刻看医生。

14.2 Don't get into a microwave or a high pressure container

Because of sudden heat or damage of sealing condition of battery, it may cause the generating, smoke, rupture or flaming.

禁止将电池放入微波炉或高压容器中

因为在密封的情况下突然受热, 可能会引起冒烟、破裂、燃烧。

14.3 Don't use a leaked battery nearby fire

If the liquid leaks from the battery (or the battery gives out bad smell), let the battery leave from flammable objects immediately. Unless do that, the electrolyte leaked from battery may catch fire and it would cause the smoke, flaming or rupture of it.

禁止将漏液的电池放到火的旁边

如果液体从电池（或者电池发出有害的气体）泄漏，假设将电池直接遗弃于易燃物体旁，如果那样做，从电池泄露出来的电解液可能会着火，而且会引也冒烟、燃烧或破裂。

14.4 Don't use an abnormal battery, such as leakage, swelling, deformation, etc.

In case the battery has bad smell, it generates, its color change or it is warped in using (includes charging and storage), let it take out from equipment or charger and do not use it. If an abnormal battery is used, it may generate bad performance or damage the device or pack.

禁止使用一个不正常的电池，像漏液、膨胀、毁坏等

万一电池有有害的气味产生，电池的颜色发生变化或它在（包括充电和贮藏）方面被弄歪，应让电池从设备或充电器中取出并且不再使用。如果一个不正常的电池被使用，它可能严重的损害设备包装。

15、Cautions:

注意

15.1 Don't use or leave the battery under the blazing sun (or in heated car by sunshine)

The battery may smoke, heat or flame. And also, it might cause the deterioration of attery's characteristics or cycle life.

禁止在高温下使用电池（或很热的汽车中）

电池可能会冒烟，过热或燃烧，它可能引起功能失效失、寿命减短。

15.2 Static Electricity

The battery has the protection circuit to avoid the danger. Do not use nearby the place where generates static electricity (more than 100V) which gives damage to the protection circuit. If the protection circuit were broken under abnormal handling, the battery would generate, smoke,rupture or flame.

静电

电池内有保护线路，不要在用静电的附近使用电池，对保护线路的伤害静的态电压（超过100）。如果保护线路在不正常的情况下被破坏，电池可能会产生冒烟、破裂或燃烧。

15.3 Manual

Please read the manual before using the battery and let it keep after reading. And also,please read it necessary.

手册

请在使用电池之前详细阅读，并保存好。请务必阅读它。

15.4 Charging Method

Please read the manual of specific charger about charging method.

充电方法

请阅读充电器手册和使用指定的充电器。

15.5 First time use

When the battery has rust, bad smell or something abnormal at first-time-using, do not use the equipment and go to the shop which it was bought.

第一使用时间

当电池有锈迹、有害的气味或者不正常的事物在第一次使用时出现，请不要使用并且去商店那买一个。

16、Others

其它

Any matters that this specification does not cover should be conferred between the customer and CEL Battery.

本说明书中未提及的事项，须经双方协商确定。

-Confidential. Please keep integrated.-

The content of this document is the exclusive property of CEL Battery, and is to be treated strictly confidential. This document shall not be allowed to us fully or partly without the written consent of CEL Battery.

此文件内容未经赛尔公司许可，请严格保密，未得到书面同意,不允许全部或部分使用。