

1 Part Numbering System

EVM	3ES	X50	B13
A	B	C	D

A:Product Code
C:Packaging Spec.

B:Type and Construction
D:Taper and Resistance

2 Appearance and Shape

2.1 Marking

Nominal Total Resistance shall be marked by 2 digits.
Please refer to table noted right side.

Nominal Total Resistance	Marking
100 ohm	12
1 k ohm	13
10 k ohm	14
1 M ohm	16

2.2 Dimensions in mm(not to scale)

General Tolerance ± 0.3

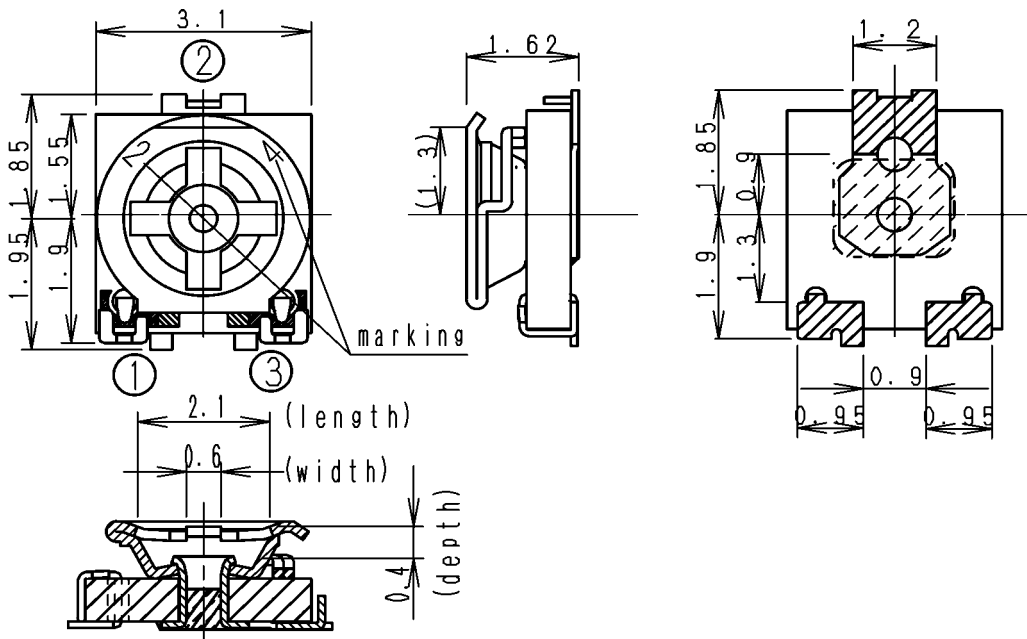

Recommended Land Pattern

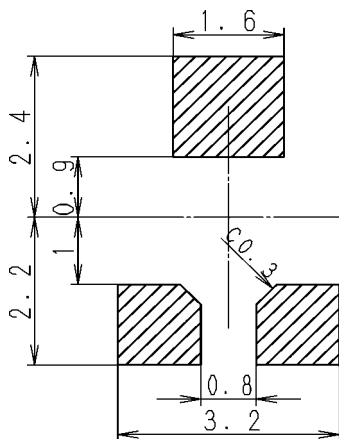

Circuit Diagram

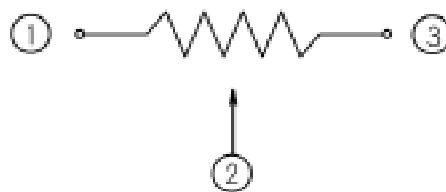

Part Name 3mm Square Trimmer Potentiometers	Issue	Revisions
Part No. EVM3ESX50B**	Drawing No. EVM3ESE00 4	1/9

2.3 Constructions and Part List

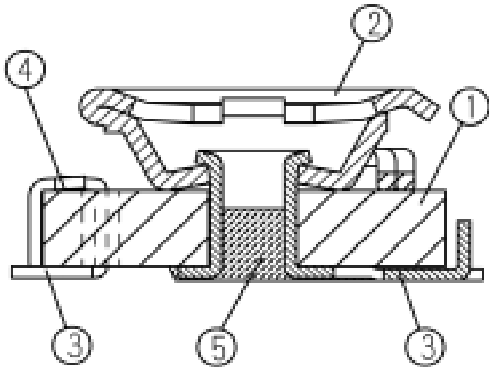

NO	Parts	Materials	Notes
1	Resistor Base	Base Alumina Resist. Metalgraze	
2	Brush	Stainless Steel	
3	Terminal	Stainless Steel	Tin Plating
4		Solder	Tin, Silver, Copper Alloy Solder
5	Coating	UV Resin	

3 Performance

3.1 Rating

Item	Performance	Remarks
Power Rating	0.15 W For potentiometers operated in ambient temperature above 70 deg.C , Power Rating shall be derated in accordance with the figure at right.	<p>Power Derating Curve</p> <p>Voltage Rating</p> $E = \sqrt{P \times R}$ <p>E: Voltage Rating(V) P: Power Rating(W) R: Nominal Total Resistance (ohm)</p>
Maximum Operating Voltage	50 V [DC]	
Voltage Rating	Voltage Rating should be Maximum Operating Voltage when E shall exceed Maximum Operating Voltage.	
Operating Temperature Range	-40 deg.C to 100 deg.C	
Nominal Total Resistance	100 ohm to 1 M ohm	
Tolerance of Total Resistance	± 25 %	

Part Name
3mm Square Trimmer Potentiometers

Issue Revisions

Part No.
EVM3ESX50B**

Drawing No.
EVM3ESE00 4

2/9

3.2 Characteristics

3.2.1 Electrical Characteristics

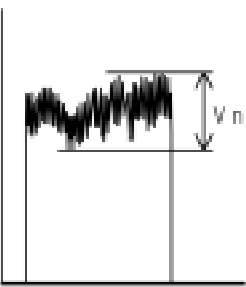
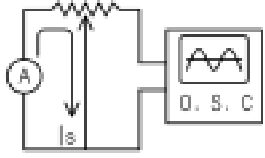
Item	Performance	Test Methods								
Resistance Law	0B (Linear)	Conforming to JIS C 5260-1 4.9								
Minimum Resistance	Shall be below 2 % of Nominal Total Resistance.	Conforming to JIS C 5260-1 4.7								
Temperature Coefficients of Resistance	Shall be within $\pm 250 \times 10^{-6} / \text{deg.C}$	Conforming to JIS C 5260-1 2.2.19								
Sliding Noise	<p>Shall be below 5 % of Nominal Total Resistance.</p> $\frac{V_n / I_s}{R} \times 100 \leq 5 \%$ <p> V_n : Noise voltage I_s : Test current R : Nominal Total Resistance </p>  <p style="text-align: right;">Noise voltage</p>	<p>Conforming to JIS C 5260-1 4.15 method B.</p> <p>Constant current power source</p>  <p>Oscilloscop or X-Y recorder</p> <p>Except both terminations. Operating rate of actuator at measurement 5 s/cycle to 15 s/cycle</p> <p>Test current $I_s = 100 \times a / R (\text{mA})$</p> <table border="1" data-bbox="981 1193 1417 1373"> <thead> <tr> <th>R: Nominal Total Resistance</th> <th>a</th> </tr> </thead> <tbody> <tr> <td>less than 10 k ohm</td> <td>10</td> </tr> <tr> <td>more than 10 k ohm and less than 1 M ohm</td> <td>100</td> </tr> <tr> <td>more than 1 M ohm</td> <td>1000</td> </tr> </tbody> </table>	R: Nominal Total Resistance	a	less than 10 k ohm	10	more than 10 k ohm and less than 1 M ohm	100	more than 1 M ohm	1000
R: Nominal Total Resistance	a									
less than 10 k ohm	10									
more than 10 k ohm and less than 1 M ohm	100									
more than 1 M ohm	1000									

Part Name 3mm Square Trimmer Potentiometers	Issue	Revisions
Part No. EVM3ESX50B**	Drawing No. EVM3ESE00	4 3/9

3.2.2 Mechanical Characteristics

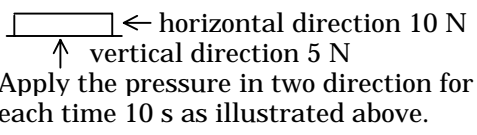
Item	Performance	Test Methods
Angle of Rotation	Electrically Effective Range 260 ° ± 20 °	Conforming to JIS C 5260-1 4.4.6
Rotation Torque	2 mN·m to 20 mN·m	Conforming to JIS C 5260-1 4.18
Adhesion	No damage on appearance, mechanical and electrical performance.	<ul style="list-style-type: none"> After mounting SMD at recommended land pattern on the test printed wiring board. 
Resistance to Vibration	$\frac{\Delta V_{12}}{V_{13}} \times 100 \leq \pm 2$ $\frac{V_{12}}{V_{13}} \times 100 \leq \pm 2$:Input voltage (terminal 1-3) :Output voltage (terminal 1-2) ΔV ₁₂ : change of V ₁₂	<ul style="list-style-type: none"> Frequency range : 10 Hz to 55 Hz Peak to peak amplitude : 1.5 mm Sweeping : 5 min/cycle Test duration : 2 h in each directions(X,Y,Z) (6 h in total) Brush setting point : middle point
Shock	$\frac{\Delta V_{12}}{V_{13}} \times 100 \leq \pm 2$ $\frac{V_{12}}{V_{13}} \times 100 \leq \pm 2$:Input voltage (terminal 1-3) :Output voltage (terminal 1-2) ΔV ₁₂ : change of V ₁₂	<ul style="list-style-type: none"> Wave form : Half-sine pulse Peak acceleration : 981 m/s² Duration of pulse : 6 ms Number of times : 3 times in each directions(X,Y,Z) (18 times in total) Brush setting point : middle point
Resistance to Soldering Heat	Total resistance change shall be within ± 2 % of initial value and no damage on appearance.	Conforming to 4.1 Mounting Notes,Soldering Method(1). • Number of times : 1 time
Solderability	New solder should be wet on the electrode and be raised, and wet angle of the solder should be less than 90degree.	Reflow soldering should be done on the print board for the test by the recommended land pattern. • Solder paste :Sn-3.0Ag-0.5Cu(RMAtype) • Paste thickness :150 μ m • Reflow conditions :Peak-temp. 250 deg.C maximum 230 deg.C or more time 30 s to 40 s

Part Name
3mm Square Trimmer Potentiometers

Issue

Revisions

Part No.
EVM3ESX50B**Drawing No.
EVM3ESE00 44
9

3.2.3 Environmental Characteristics

Item	Performance	Test Methods
Resistance to Cold	Total resistance change shall be within $\pm 5\%$ of initial value.	Test temperature : -40 deg.C \pm 3 deg.C Test duration : 96 h \pm 4 h Brush setting point : middle point
Resistance to Heat	Total resistance change shall be within $\pm 5\%$ of initial value.	Test temperature : 70 deg.C \pm 2 deg.C Test duration : 500 h \pm 12 h Brush setting point : middle point
Change of Temperature	Total resistance change shall be within $\pm 5\%$ of initial value.	Low temperature : -40 deg.C \pm 3 deg.C, 30 min High temperature : 85 deg.C \pm 2 deg.C, 30 min Room temperature : 5 min Number of temperature change cycle : 50 cycle Brush setting point : middle point
Resistance to Damp, Heat	Total resistance change shall be within $\pm 5\%$ of initial value.	Test temperature : 60 deg.C \pm 2 deg.C Relative humidity : 90 %RH to 95 %RH Test duration : 500 h \pm 12 h Brush setting point : middle point
Endurance (Under Damp, Load)	Total resistance change shall be within $\pm 5\%$ of initial value.	Test temperature : 60 deg.C \pm 2 deg.C Relative humidity : 90 %RH to 95 %RH Test duration : 500 h \pm 12 h Load : Votage Rating Loading method : 1.5 h on and 0.5 h off (across terminations 1 and 3) Brush setting point : middle point
Endurance (Under Rated Load)	Total resistance change shall be within $\pm 5\%$ of initial value.	Test temperature : 70 deg.C \pm 2 deg.C Test duration : 500 h \pm 12 h Load : Votage Rating Loading method : 1.5 h on and 0.5 h off (across terminations 1 and 3) Brush setting point : middle point
Endurance (To Sliding)	Total resistance change shall be within $\pm 15\%$ of initial value.	Number of test revolution : 20 revolution (without electrical load) Revolutional speed : 5 /min to 10 /min One revolution means more than 90 % of the total electrical range.

3mm Square Trimmer Potentiometers

Issue

Revisions

EVM3ESX50B**

Drawing No.

EVM3ESE00

4

5

9

4 Application Notes

4.1 Mounting Notes

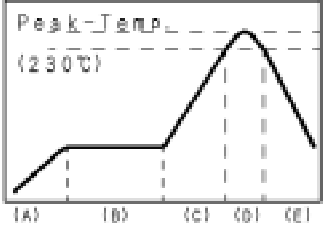
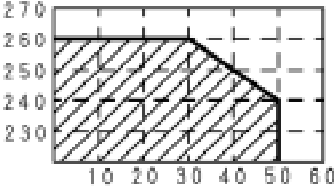
<p>Reflow Soldering</p>	<p>When reflow soldering, please observe below conditions.</p> <p>[Reflow Soldering Profile]</p>  <p>Temp. (deg.C)</p> <p>Time(s)</p> <p>(A)Heat-up zone 1 Room-temp. to preheat zone: 30 s to 60 s</p> <p>(B)Preheat zone 140 deg.C to 180 deg.C : 60 s to 120 s</p> <p>(C)Heat-up zone 2 Preheat zone to 230 deg.C : 20 s to 40 s</p> <p>(D)Melting-heat zone Peak-temp. : 5 s max</p> <p>Refer to the following (230 deg.C or more) graph.</p> <p>(E)Cooling zone 200 deg.C to 100 deg.C : 1 deg.C/s to 4 deg.C/s</p> <p>[Recommended condition]</p>  <p>Peak Temp. (deg.C)</p> <p>Time(s)(230 deg.C or more)</p> <p>(1)In case of reflow soldering,please measure actual temp. on the product surface and observe recommended condition described left.</p> <p>(2)In case of exceeding recommended condition, please consult with us before use.</p> <p>(3)The temp. strongly depends on measuring method of profile, please note how to do it.</p> <p>(4)In case that temp.changes by PWB size, mounting density and so on, please check them by each PWB.</p>
<p>Manual Soldering</p>	<p>When manual soldering, please observe below condition.</p> <ul style="list-style-type: none"> • Soldering iron : 20 W maximum • Soldering iron tip temperature : 280 deg.C maximum • Soldering time : 3 s maximum
<p>Soldering Notes (1)</p>	<p>This trimmer potentiometer is available for reflow soldering and manual soldering only.</p>
<p>Soldering Notes (2)</p>	<p>Solder and flux dissipated on the surface of element and contactor cause fatal damage, therefore in case of making wash and rinse, please consult before use.</p>

(2)Design PCB

When designing land pattern, please design it,in accordance with recommended land layout described in this production specifications for information.

(3)Mounting Notes

Mounting top side pressure loaded on the trimmer potentiometer shall be 4.9 N maximum. Overload is afraid to cause fatal damage as transform or breakdown. After soldering ,solder ball or solder scrap may cause short between the land pattern,so please make enough insulation there.

(4)Adjustment Notes

Adjusting top side pressure loaded on the contactor shall be 4.9 N maximum. Overload is afraid to cause fatal damage as transform or breakdown of adjustment knob. In case that the moving contact is set near the border portion between electrically effective and non-effective range ,electrically non-effective and open range, be afraid to be deviation of setting value. So avoid the setting like this.

(5)Lock paint

Avoid applying any lockpaint otherwise intrusion or dissipation of the paint may cause contact dectect. In case of being subjected to apply it,please avoid using adhesives that may generate corrosive gas.

<p>part Name 3mm Square Trimmer Potentiometers</p>	<p>Issue Revisions</p>
<p>Part No. EVM3ESX50B**</p>	<p>Drawing No. EVM3ESE00 4</p> <p style="text-align: right;">6/9</p>

4.2 Circuit Diagram Notes

(1) Power Rating

The Maximum value of electric power which can continuously dissipated from all area of a resistive element at the rated ambient temperature.

In general, rated power shall be registered in accordance with size & kind of them.

Please observe to use below rated power. Continuously dissipation is afraid to cause fatal damage, for example, deviation, firing, smoking.

(2) Influence of ambient temperature

Influence of ambient temperature can not be neglected for operating trim-pot in general case.

Please comply with power derated curve, in case of using it under the condition of exceeding specified power rating.

4.3 Mounting Notes

This trimmer potentiometer is not available for sealed type, so this is afraid to be influenced fatally under the following conditions.

(1) Corrosive gas atmosphere of Cl, H₂S, NH₃, NO_x, SO₂ and so on.

(2) Moisture atmosphere of waterdrop, dewdrop and so on.

(3) Water, Salt, oil, chemicals, solvents and so on.

(4) Atmosphere of direct solar radiation.

4.4 Storage Notes

Storage under the following condition should be avoided.

Be afraid to degrade some performances and soldering wettability.

(1) Temperature: less than -10 deg.C and more than 40 deg.C,

Relative humidity: more than 85 %.

(2) Atmosphere of corrosive gas.

(3) Long term storage of over 6 months after delivery.

(4) Atmosphere of direct solar radiation.

Please store the package without unsuitable load and stress.

While remaining some product after opening the package, any countermeasure of shutting moisture gas and so on, should be done.

4.5 Application Notes for electric equipments and instruments

Although enough care is taken to ensure trimmer potentiometer quality.

As life-end breakage mode, some fatal trouble might generate, such as spec-out resistance change, short or open circuits, abnormally generated heat.

So please review the affect of any single fault of a potentiometer in advance.

(1) The product specification for information ensures the quality of pre-set potentiometers.

For applying, please should evaluate this product under the condition built in the appliances.

(2) The troubles caused by applying this product under out-specification should not be warranted.

(3) When applying for high-excellent liability and security appliances, for example, traffic transportation equipments (train, auto vehicles, traffic-signal equipments), medical apparatus, aircraft, spacecraft, heating, firing, gas, rotating equipment, security equipment, atomic-power equipment, machine-tool, and so on.

Please make enough considerations to design fail-safe circuit system for safety as followings.

*To make a safety system by a protective circuit or a protective device.

*To make a safety system by the redundant circuit so that the single fault of a trimmer potentiometer does not cause a dangerous situation.

(4) In case of arising some questions on the safety of this product, please don't hesitate to contact with our company and further technical evaluation should be done.

Part Name 3mm Square Trimmer Potentiometers	Issue	Revisions
Part No. EVM3ESX50B**	Drawing No. EVM3ESE00 4	7 9

5 Operation of product specification for information

- (1) Please return one set specification as approval one with accepted stamp or sign, after confirming and checking it.
 In case that it will not be returned, in spite of taking three months or more from issue date noted on the cover page of this specification.
 We could estimate that it has been already accepted, so please consider to operate it.
- (2) Changing the content of product of specification for information is to be performed after pre-coordination with customer.
- (3) The valid term of product specification for information shall be 5 years from our issue date in principle. For improving the content of it through the relation between Industrial Association and some related standards, the revision of raw materials and process conditions, the reflection of security level.
 While the valid term noted on the cover-page shall be preferential individually. By 3 months before due-date, unless otherwise specified (including requests from customers), the valid term of product specification for information shall be extended for one year automatically and same after this.

Part Name 3mm Square Trimmer Potentiometers	Issue	Revisions	
Part No. EVM3ESX50B**	Drawing No. EVM3ESE00	4	8/9

6 Packaging Methods

<Carrier Tape>

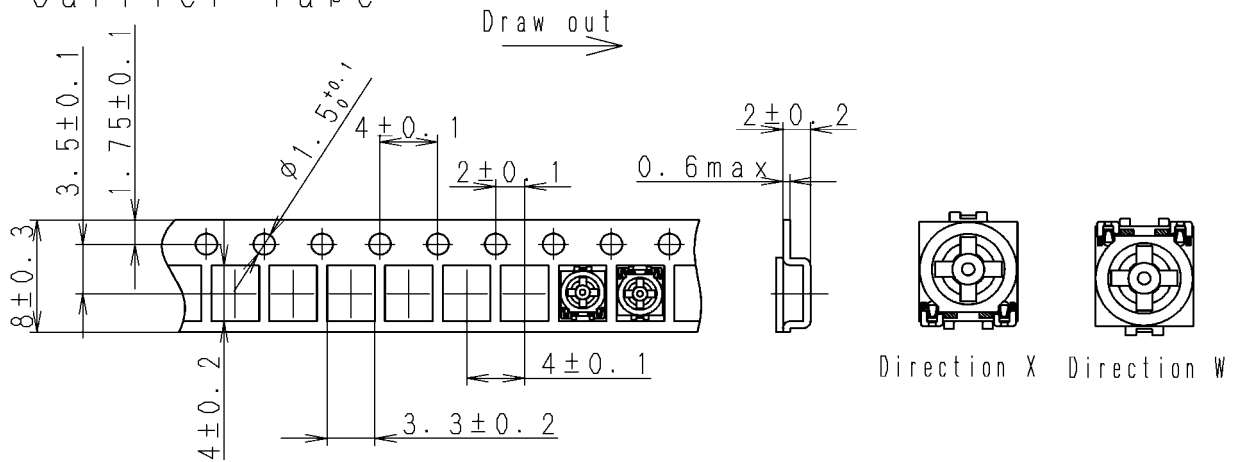

<Reel>

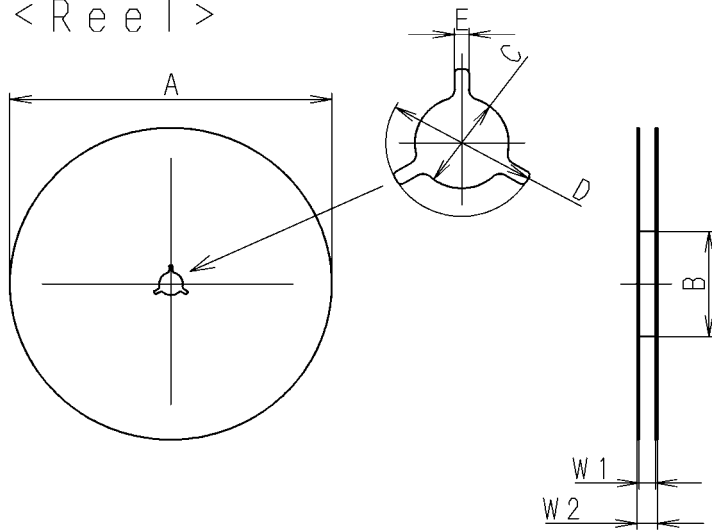

<Quantity>

NO	Part Number	Quantity/Reel
1	EVM3ESX50B** (W)	2000

NO	A	B	C	D	E	W1	W2
1	178	60	13	21	2	8.4	14.4
Tolerance	±2	min.	±0.2	±0.8	±0.5	+2 -0	max.

<Taping Methods>

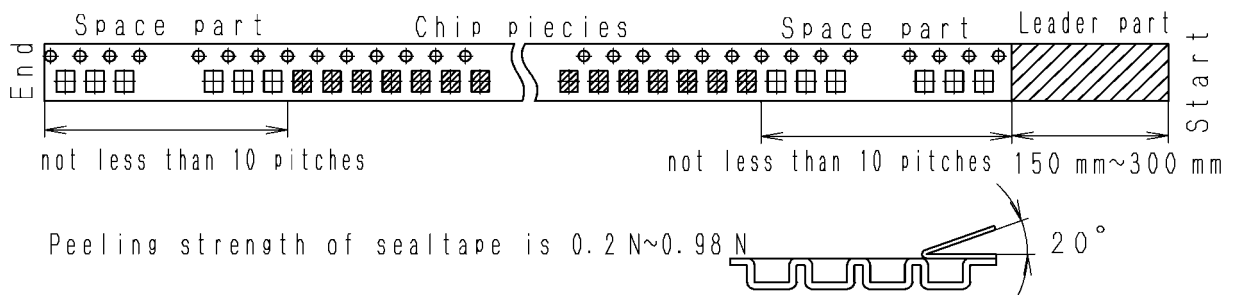

Part Name 3mm Square Trimmer Potentiometers	Issue	Revisions
Part No. EVM3ESX50B**	Drawing No. EVM3ESE00 4	9 9