

电 气 参 数

Electrical Specifications

型号	Holder Type	6x3.5mm Ceramic Surface Mount
频率范围	Frequency Range	10.000 to 150.000 MHZ
调整频差	Frequency Tolerance (ΔF) (at25°C)	$\pm 10\text{ppm}$ to $\pm 100\text{ppm}$
温度频差	Frequency Drift	$\pm 10\text{ppm}$ to $\pm 100\text{ppm}$
工作温度范围	Operating Temperature Range	-10°C - +60°C to -40°C - +85°C
储存温度范围	Storage Temperature Range	-40°C - +85°C/-55°C - +125°C
老化	Aging (25°C)	$\pm 5\text{ppm/ year}$ Maximum
静电容	Shunt Capacitance (C0)	7pF maximum
激励功率	Drive Level	100uW Typical
绝缘阻抗	Insulation Resistance (Rs)	500 Megaohms Minimum at D.C100V
负载电容	Load Capacitance (CL)	Suggested by customer

外 型 尺 寸

Mechanical Dimensions

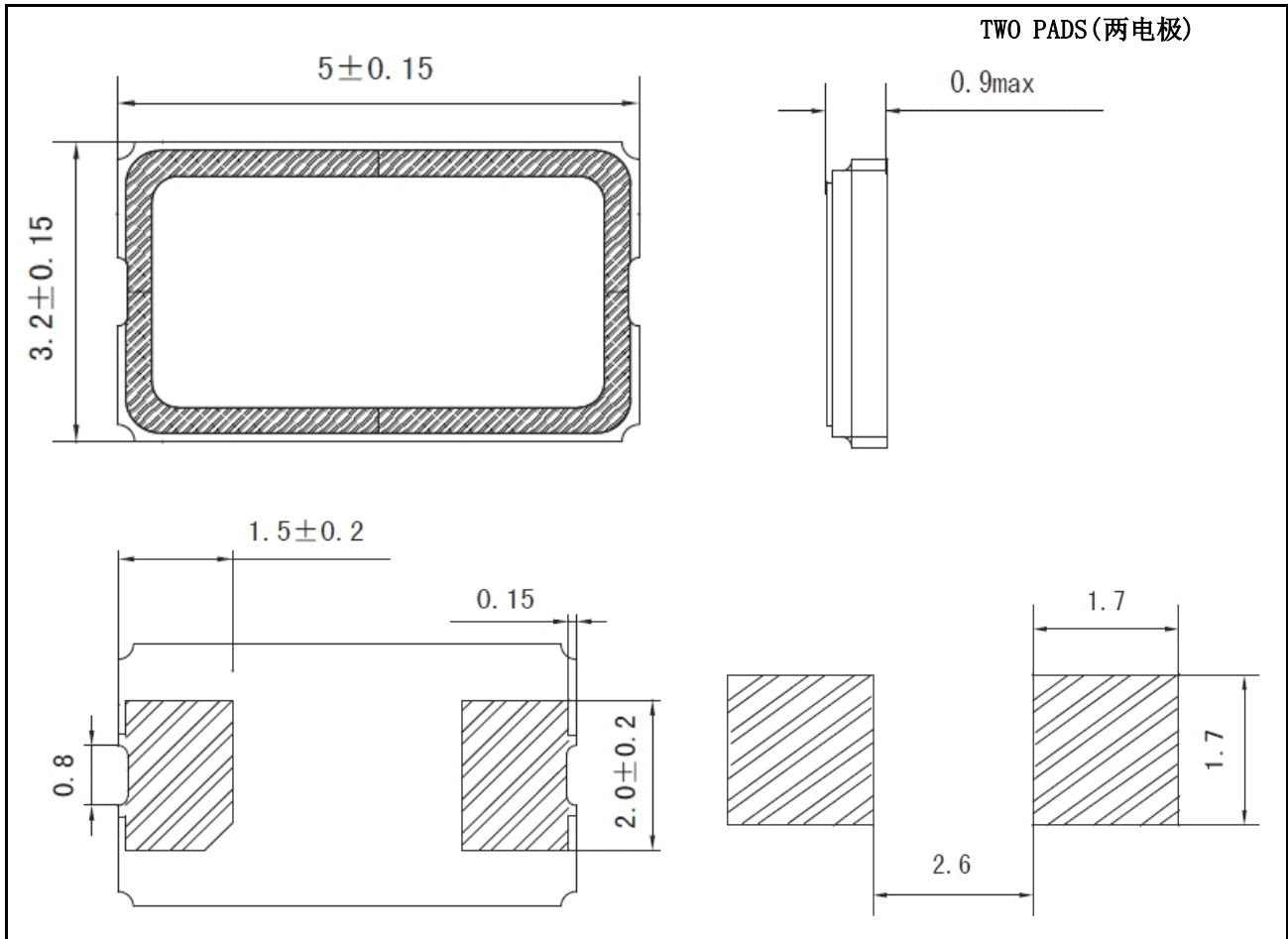

外型尺寸

Mechanical Dimensions

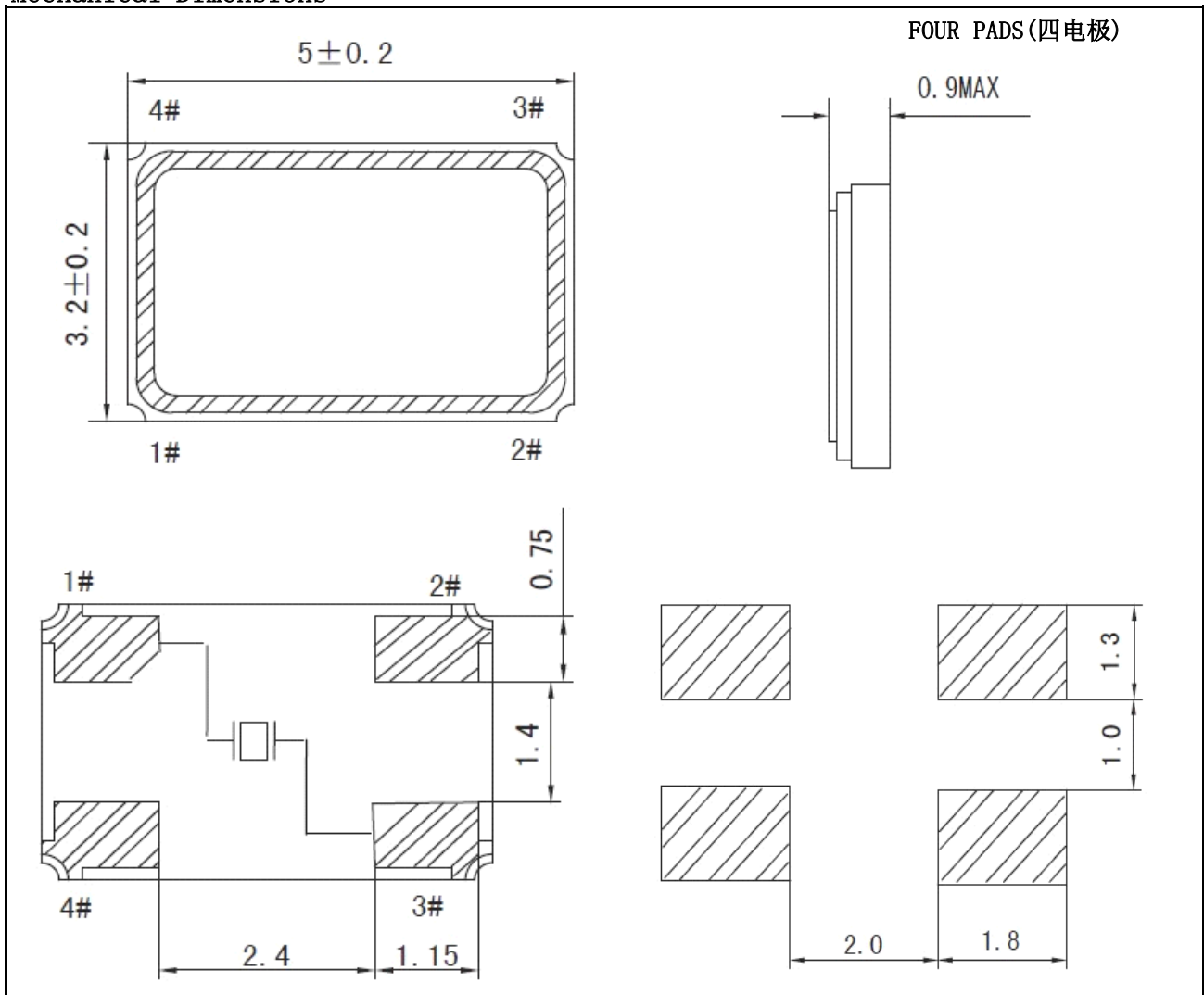

等效阻抗和振荡模式

Equivalent Series Resistance and Mode of Operation

Frequency Range 频率范围	ESR (Ω) 等效阻抗	Mode 振荡模式
10.000 to 12.000 MHZ	80Max	基频Fundamental
12.000 to 16.000 MHZ	60Max	Fundamental
16.000 to 20.000MHZ	50Max	Fundamental
20.000 to 24.001MHZ	40Max	Fundamental
24.000 to 50.002MHZ	30Max	Fundamental
40.000 to 60.000MHZ	100Max	三次泛音Third Overtone
60.000 to 150.000MHZ	80Max	Third Overtone

Tel: 0086-0755-29236652 29236692

Fax: 0086-0755-29236659

E-mail: wu@songjicn.com

http://www.songjicn.com