

△	△	△	△	△	△
人数	打立総数	担当者	年月日	承認者	

NOTES :

1. Housing material : Heat resistant plastic UL94V-0, Black
 2. Terminal material : Copper Alloy
 3. Terminal plated : Gold plating over all, Nickel (Min 40 μ) plating over all
 4. Part No. : ASE6HXX10
- Contacts No. 

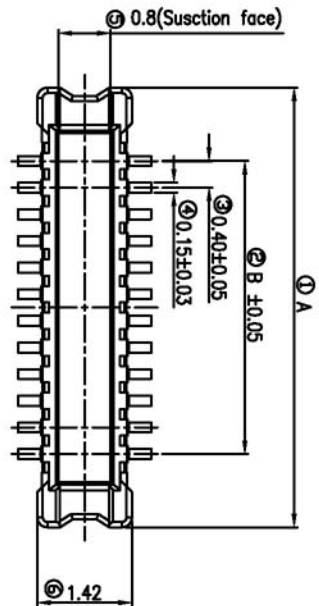

Mating drawing

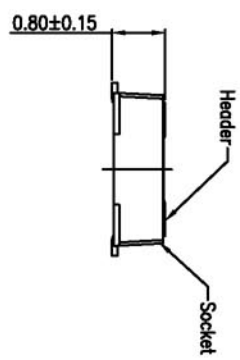

Dimension table (mm)

No. of contacts	Dimension	
	A	B
10	3.80	1.60
12	4.20	2.00
14	4.60	2.40
16	5.00	2.80
20	5.80	3.60
22	6.20	4.00
24	6.60	4.40
30	7.80	5.60
36	9.00	6.80
40	9.80	7.60
50	11.80	9.60
60	13.80	11.60
70	15.80	13.60
80	17.80	15.60

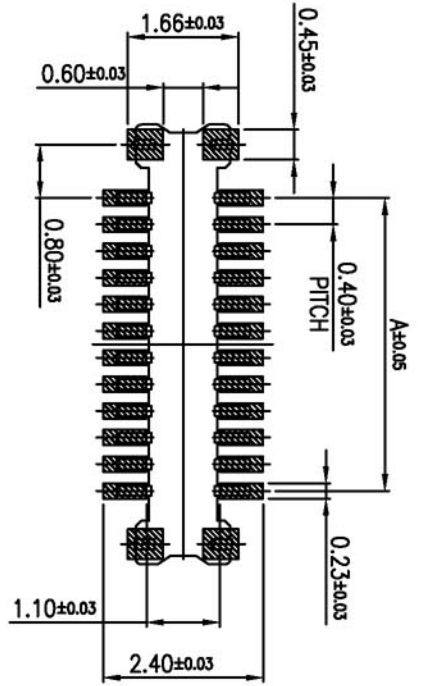

Recommended PC board pattern
(mounting pad layout)

ATC		ASSEM TECHNOLOGY CO., LTD.		TITLE		0.4mm Pitch BOARD TO BOARD MATED HEIGHT 0.80mm HEADER CONNECTOR	
DRAWING CHECKED	JERRY STING	MATERIAL APPROVED	Heat resistant plastic (94-V0)	P / N	ASE6H * * 10	REV.	A
APPROVED	JACK		TOLERANCE UNLESS OTHER WISE SPEC.	UNIT	mm	DATE	2011/5/30
				General tolerance : ±0.2			

