



MBRF1040CTG THRU MBRF10200CTG

10.0 AMPS. Isolated Schottky Barrier Rectifiers

Features

- Metal silicon junction, majority carrier conduction
- Plastic material used carries Underwriters Laboratory Classifications 94V-0
- High surge capability
- Low power loss, high efficiency
- High current capability, low forward voltage drop
- For use in low voltage, high frequency inverters, free wheeling, and polarity protection applications
- Guardring for overvoltage protection
- High temperature soldering guaranteed: 260°C/10 seconds, at terminals
- Green compound with suffix "G" on packing code & prefix "G" on datecode.

TO-220

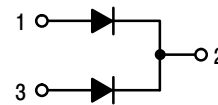
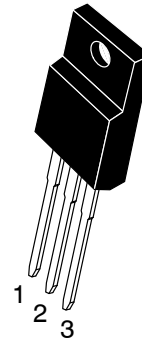

Mechanical Data

- Case: TO-220 molded plastic body
- Polarity: As marked
- Terminals: Pure tin plated, lead free. solderable per MIL-STD-750, Method 2026
- Mounting position: Any
- Weight: 1.74grams
- Mounting torque: 5 in. - lbs. max

Marking Diagram



Y = Year
 A = Assembly Location
 WW = Work Week
 MBRF10XX = Specific Device Code

Maximum Ratings and Electrical Characteristics

Rating at 25 °C ambient temperature unless otherwise specified.
 Single phase, half wave, 60 Hz, resistive or inductive load.
 For capacitive load, derate current by 20%

Type Number	Symbol	MBRF 1040 CTG	MBRF 1045 CTG	MBRF 1050 CTG	MBRF 1060 CTG	MBRF 1080 CTG	MBRF 10100 CTG	MBRF 10150 CTG	MBRF 10200 CTG	Unit								
Maximum Repetitive Peak Reverse Voltage	V_{RRM}	40	45	50	60	80	100	150	200	V								
Maximum RMS Voltage	V_{RMS}	28	31	35	42	56	70	105	140	V								
Maximum DC Blocking Voltage	V_{DC}	40	45	50	60	80	100	150	200	V								
Maximum Average Forward Rectified Current at $T_c=133^\circ\text{C}$	$I_{F(AV)}$	10								A								
Peak Repetitive Forward Current (Rated VR, Square Wave, 20KHz) at $T_c=133^\circ\text{C}$	I_{FRM}	20								A								
Peak Forward Surge Current, 8.3 ms Single Half Sine-wave Superimposed on Rated Load (JEDEC method)	I_{FSM}	150								A								
Peak Repetitive Reverse Surge Current (Note 1)	I_{RRM}	0.5								A								
Maximum Instantaneous Forward Voltage (Note 2) $I_F=5A, T_A=25^\circ\text{C}$ $I_F=5A, T_A=125^\circ\text{C}$ $I_F=10A, T_A=25^\circ\text{C}$ $I_F=10A, T_A=125^\circ\text{C}$	V_F	0.70	0.55	0.78	0.67	0.80	0.65	0.90	0.75	0.80	0.70	0.95	0.85	0.88	0.78	0.98	0.88	V
Maximum Reverse Current @ Rated VR $T_A=25^\circ\text{C}$ $T_A=125^\circ\text{C}$	I_R	0.1								mA								
		15	10	5														
Voltage Rate of Change (Rated V_R)	dV/dt	10000								V/us								
Typical Thermal Resistance Per Leg	$R_{\theta JC}$	3.5								$^\circ\text{C/W}$								
Operating Temperature Range	T_J	- 65 to + 175								$^\circ\text{C}$								
Storage Temperature Range	T_{STG}	- 65 to + 150								$^\circ\text{C}$								

Note 1: 2.0uS Pulse Width, f=1.0KHz

Note 2: Pulse Test : 300uS Pulse Width, 1% Duty Cycle

RATINGS AND CHARACTERISTIC CURVES

FIG. 1 FORWARD CURRENT DERATING CURVE

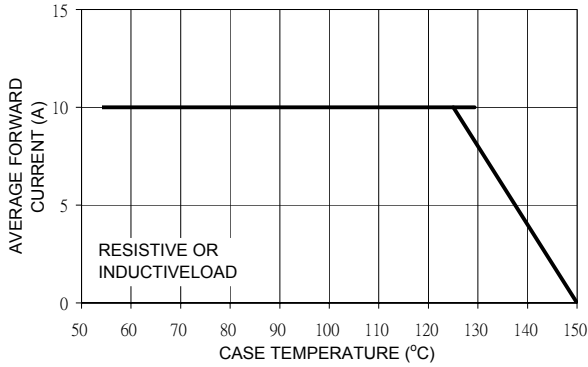

FIG. 2 MAXIMUM NON-REPETITIVE FORWARD SURGE CURRENT PER LEG

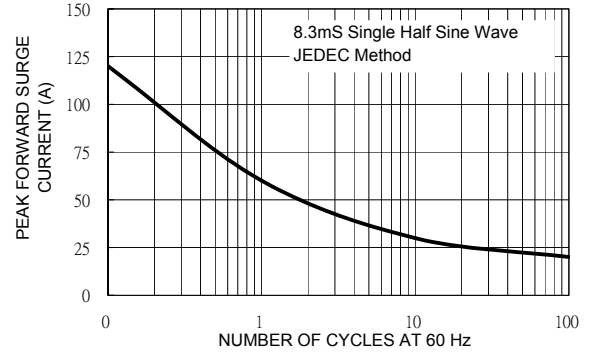

FIG. 3 TYPICAL FORWARD CHARACTERISTICS PER LEG

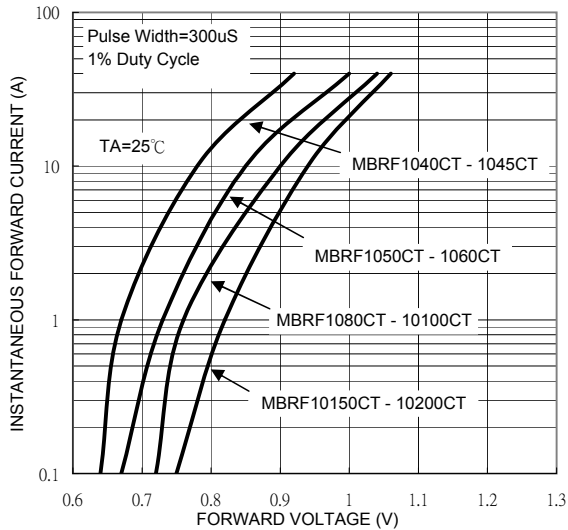

FIG. 4 TYPICAL REVERSE CHARACTERISTICS PER LEG

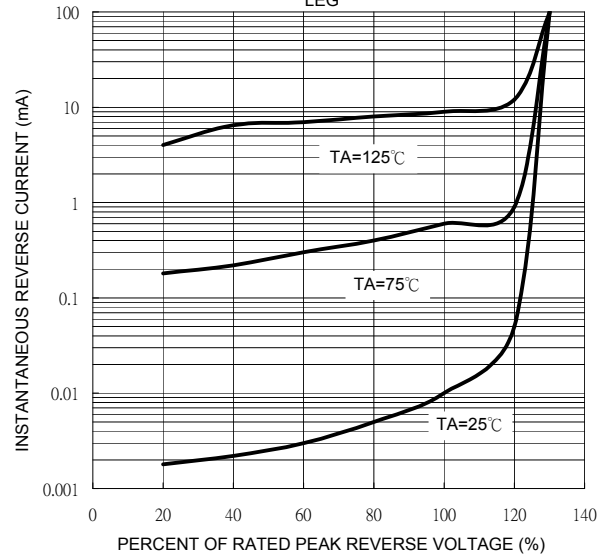

FIG. 5 TYPICAL JUNCTION CAPACITANCE PER LEG

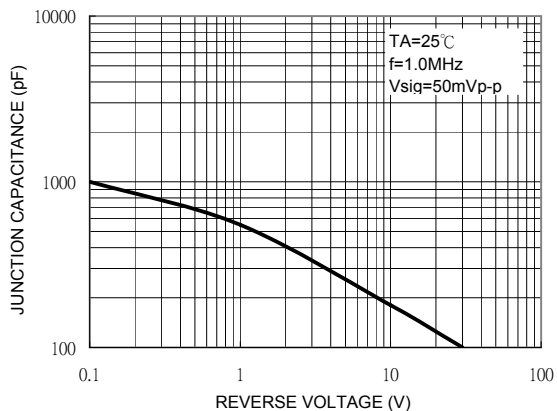
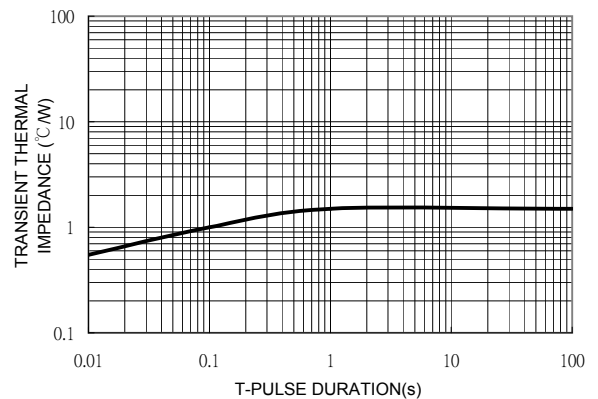
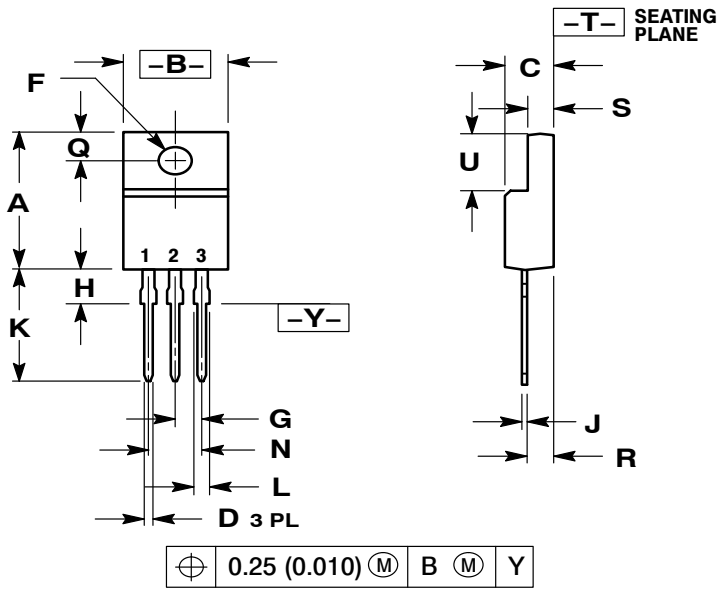

FIG. 6 TYPICAL TRANSIENT THERMAL IMPEDANCE PER LEG



TO-220



NOTES:

1. DIMENSIONING AND TOLERANCING PER ANSI Y14.5M, 1982.
2. CONTROLLING DIMENSION: INCH
3. 221D-01 THRU 221D-02 OBSOLETE, NEW STANDARD 221D-03.

DIM	INCHES		MILLIMETERS	
	MIN	MAX	MIN	MAX
A	0.617	0.635	15.67	16.12
B	0.392	0.419	9.96	10.63
C	0.177	0.193	4.50	4.90
D	0.024	0.039	0.60	1.00
F	0.116	0.129	2.95	3.28
G	0.100 BSC		2.54 BSC	
H	0.118	0.135	3.00	3.43
J	0.018	0.025	0.45	0.63
K	0.503	0.541	12.78	13.73
L	0.048	0.058	1.23	1.47
N	0.200 BSC		5.08 BSC	
Q	0.122	0.138	3.10	3.50
R	0.099	0.117	2.51	2.96
S	0.092	0.113	2.34	2.87
U	0.239	0.271	6.06	6.88