

## SLVU2.8 Ultralow Capacitance Transient Voltage Suppressors

### General Description

The Ultralow Capacitance Transient Voltage Suppressors are designed to low voltage, integrated circuits from transients caused by electrostatic discharge (ESD), electrical fast transients (EFT), tertiary lightning and other induced voltages.

### Applications

- Ethernet – 10/100/1000 Base T
- WAN/LAN Equipment
- Desktops, Servers, Notebooks & Handhelds
- Laser Diode Protection

### Features

- 400 W Peak Pulse Power per Line ( $t_p=8/20\mu s$ )
- One Device Protects one Unidirectional Line.
- Low Capacitance.
- Low Leakage Current.
- Low Operating and Clamping Voltages.
- Transient Protection for High Speed Data Lines to  
**IEC61000-4-2(ESD)  $\pm 15kV$ (air),  $\pm 8kV$ (Contact)**  
**IEC61000-4-4(EFT) 40A(5/50ns)**  
**IEC61000-4-5(lightning) 24A(8/20us)**

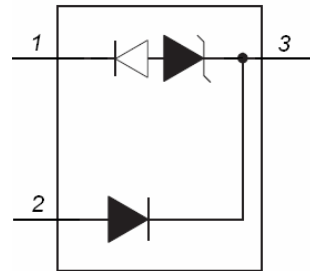
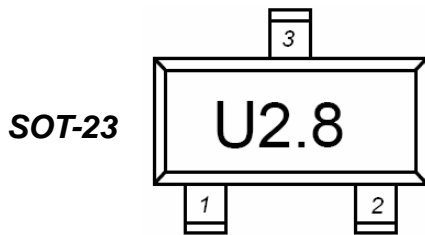

### Absolute Maximum Ratings

Parameter	Symbol	Value	Units
Peak Pulse Power ( $t_p = 8/20\mu s$ ) - See Fig1.	$P_{PK}$	400	W
Peak Pulse Current ( $t_p = 8/20\mu s$ )	$I_{PP}$	24	A
Storage Temperature Range	$T_{STG}$	-55 to 150	$^{\circ}C$
Operating Junction Temperature Range	$T_J$	-55 to 150	$^{\circ}C$

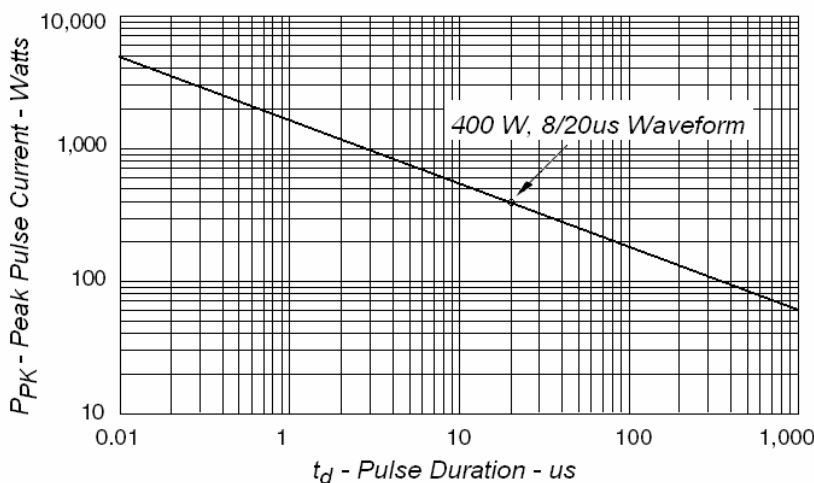

**Fig1. Peak Pulse Power VS Pulse Time**

## Electrical Parameter

Symbol	Parameter
$I_{PP}$	Peak Pulse Current
$V_C$	Clamping Voltage @ $I_{PP}$
$V_{RWM}$	Reverse Stand-Off Voltage
$I_R$	Reverse Leakage Current @ $V_{RWM}$
$V_{SB}$	Snap-Back Voltage @ $I_{SB}$
$I_{SB}$	Snap-Back Current
$V_{PT}$	Punch-Through Voltage
$I_{PT}$	Punch-Through Current
$V_{BRR}$	Reverse Breakdown Voltage @ $I_{BRR}$
$I_{BRR}$	Reverse Breakdown Current

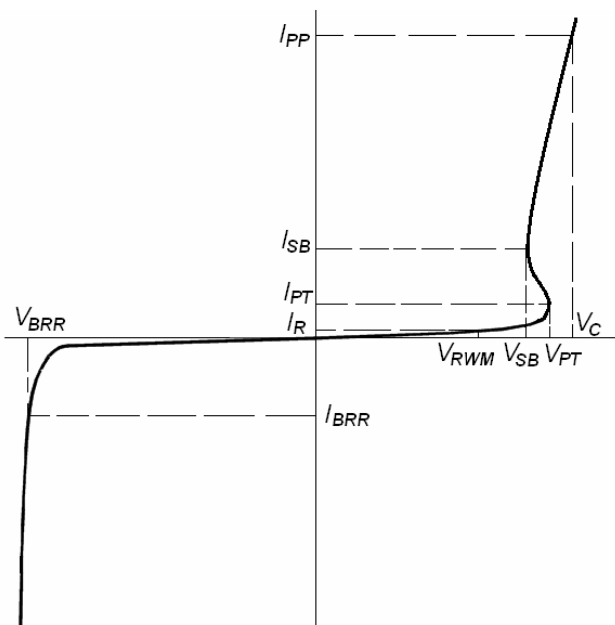

Fig2. SLVU2.8 IV Characteristic Curve

## Electrical Characteristics

Parameter	Symbol	Conditions	Minimum	Typical	Maximum	Units
Reverse Stand-Off Voltage	$V_{RWM}$	Pin 3 to 1 or Pin 2 to 1			2.8	V
Punch-Through Voltage	$V_{PT}$	$I_{PT} = 2\mu A$ , Pin 3 to 1	3.0			V
Snap-Back Voltage	$V_{SB}$	$I_{SB} = 50mA$ , Pin 3 to 1	2.8			V
Reverse Leakage Current	$I_R$	$V_{RWM} = 2.8V$ , $T = 25^\circ C$ Pin 3 to 1 or Pin 2 to 1			1	$\mu A$
Clamping Voltage	$V_C$	$I_{PP} = 2A$ , $t_p = 8/20\mu s$ Pin 3 to 1			3.9	V
Clamping Voltage	$V_C$	$I_{PP} = 5A$ , $t_p = 8/20\mu s$ Pin 3 to 1			7	V
Clamping Voltage	$V_C$	$I_{PP} = 24A$ , $t_p = 8/20\mu s$ Pin 3 to 1			12.5	V
Clamping Voltage	$V_C$	$I_{PP} = 5A$ , $t_p = 8/20\mu s$ Pin 2 to 1			8.5	V
Clamping Voltage	$V_C$	$I_{PP} = 24A$ , $t_p = 8/20\mu s$ Pin 2 to 1			15	V
Junction Capacitance	$C_j$	Pin 3 to 1 and 2 (Pin 1 and 2 tied together) $V_R = 0V$ , $f = 1MHz$		70	100	pF
Junction Capacitance	$C_j$	Pin 2 to 1 (Pin 3 N.C.) $V_R = 0V$ , $f = 1MHz$			10	pF

Steering Diode Characteristics						
Parameter	Symbol	Conditions	Minimum	Typical	Maximum	Units
Reverse Breakdown Voltage	$V_{BRR}$	$I_T = 10\mu A$ , Pin 3 to 2	40			V
Reverse Leakage Current	$I_{BRR}$	$V_{RWM} = 2.8V$ , $T = 25^\circ C$ Pin 3 to 2			1	UA
Forward Voltage	$V_F$	$I_F = 1A$ , Pin 2 to 3			2	V

Typical Characteristics

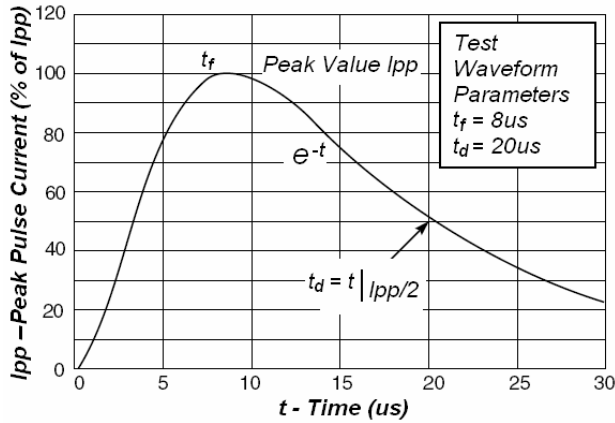

Fig3. Pulse Waveform

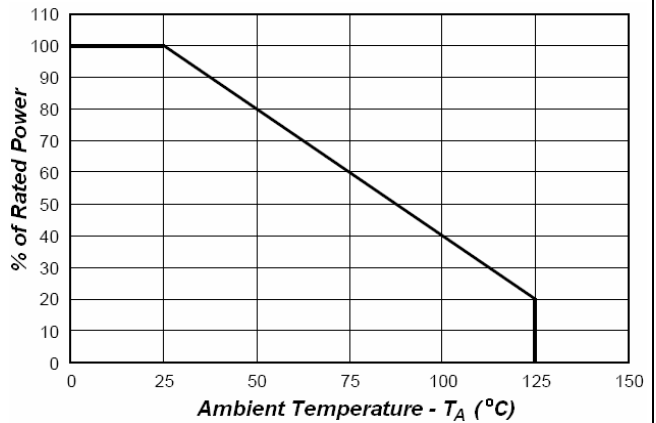

Fig4. Power Derating Curve

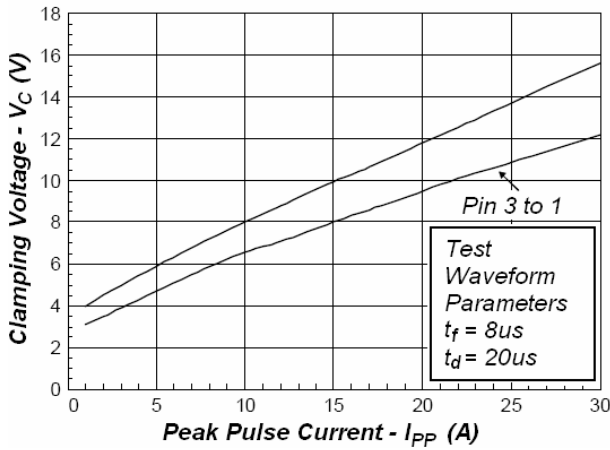

Fig5. Clamping Voltage vs. Peak Pulse Current

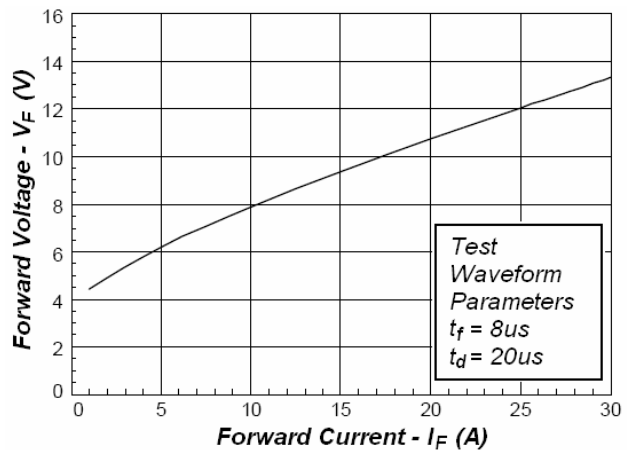
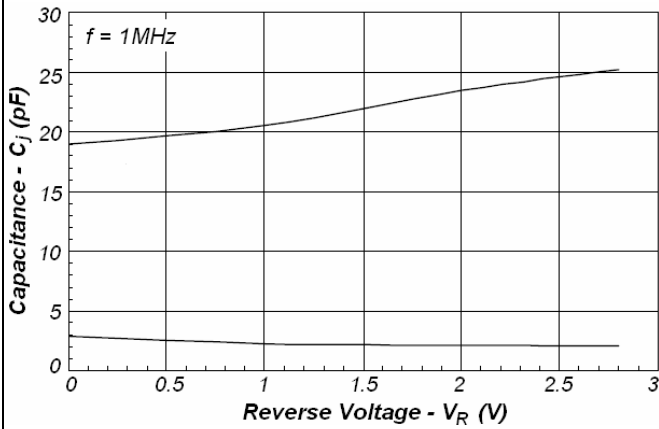
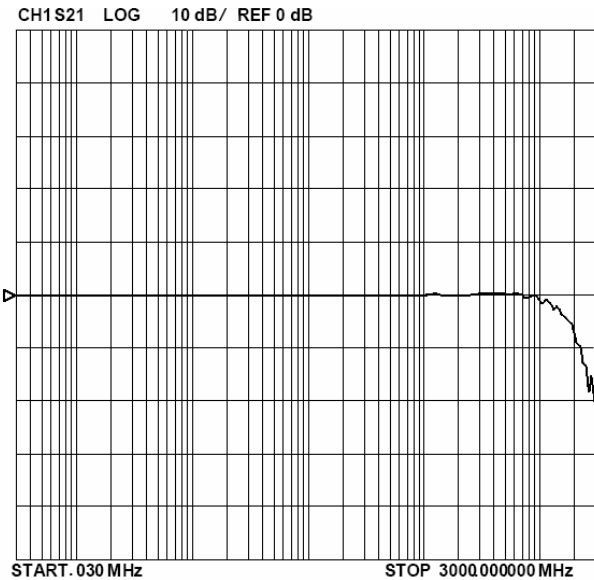

Fig6. Forward Voltage vs. Forward Current



**Fig7 Reverse Voltage vs. Capacitance**



**Fig8. Insertion Loss S21**

## Application Note

The SLVU2.8 is ideal for providing protection for electronic equipment that is susceptible to damage caused by Electrostatic Discharge (ESD), Electrical Fast Transients (EFT) and tertiary lightning effects. This product is offered in a unidirectional configuration and provides both commonmode or differential-mode protection.

### Unidirectional Common-Mode Protection (Figure 9)

The SLVU2.8 provides one line of unidirectional protection in a common-mode configuration as depicted in figure 9.

Circuit connectivity is as follows:

- Line 1 is connected to Pin 3
- Pins 1 and 2 are connected to ground

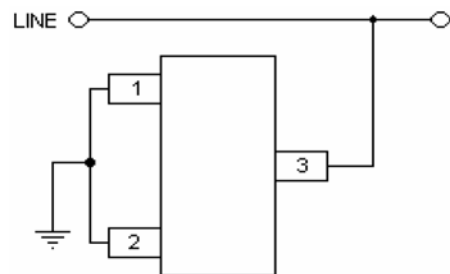

**Fig9.**

## **Bidirectional Common-Mode Protection (Figure 10)**

Two SLVU2.8 devices provide one line of bidirectional protection in a common-mode configuration as depicted in figure 10.

Circuit connectivity is as follows:

- Line 1 is connected to Pin1 of Device 1 & Pin 2 of Device 2
- Pin 2 of Device 1 and Pin 1 of Device 2 are connected to ground
- Pin 3 of both devices is not connected

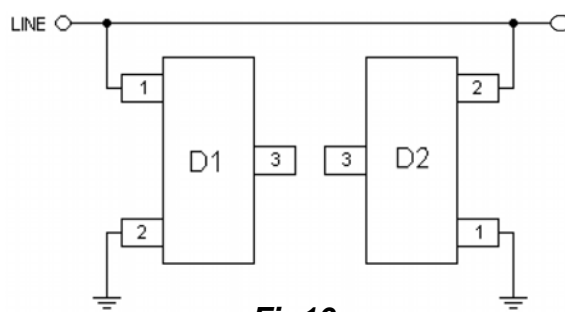

**Fig10.**

## **Bidirectional Differential-Mode Protection (Figure 11)**

Two SLVU2.8 devices provide up to two lines of bidirectional protection in a differential mode configuration as depicted in figure 11.

Circuit connectivity is as follows:

- Line 1 is connected to Pin1 of Device 1 & Pin 2 of Device 2
- Line 2 is connected to Pin 2 of Device 1 & Pin 1 of Device 2

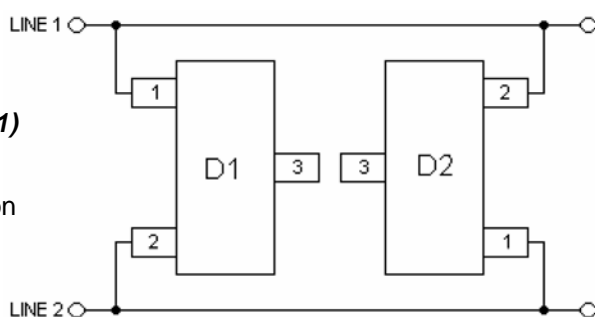

**Fig11.**

## **Circuit Board Layout Protection**

Circuit board layout is critical for Electromagnetic Compatibility (EMC) protection. The following guidelines are recommended:

- The protection device should be placed near the input terminals or connectors, the device will divert the transient current immediately before it can be coupled into the nearby traces.
- The path length between the TVS device and the protected line should be minimized.
- All conductive loops including power and ground loops should be minimized.
- The transient current return path to ground should be kept as short as possible to reduce parasitic inductance.
- Ground planes should be used whenever possible. For multilayer PCBs, use ground vias.

Typical Applications

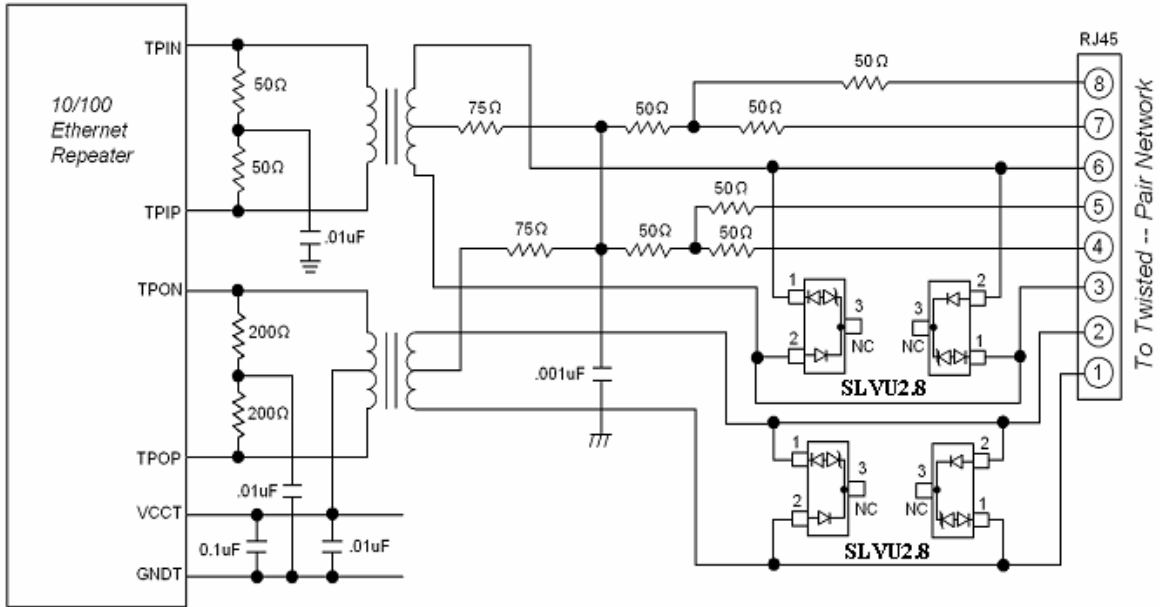

Fig12. 10/100 Ethernet Protection Circuit

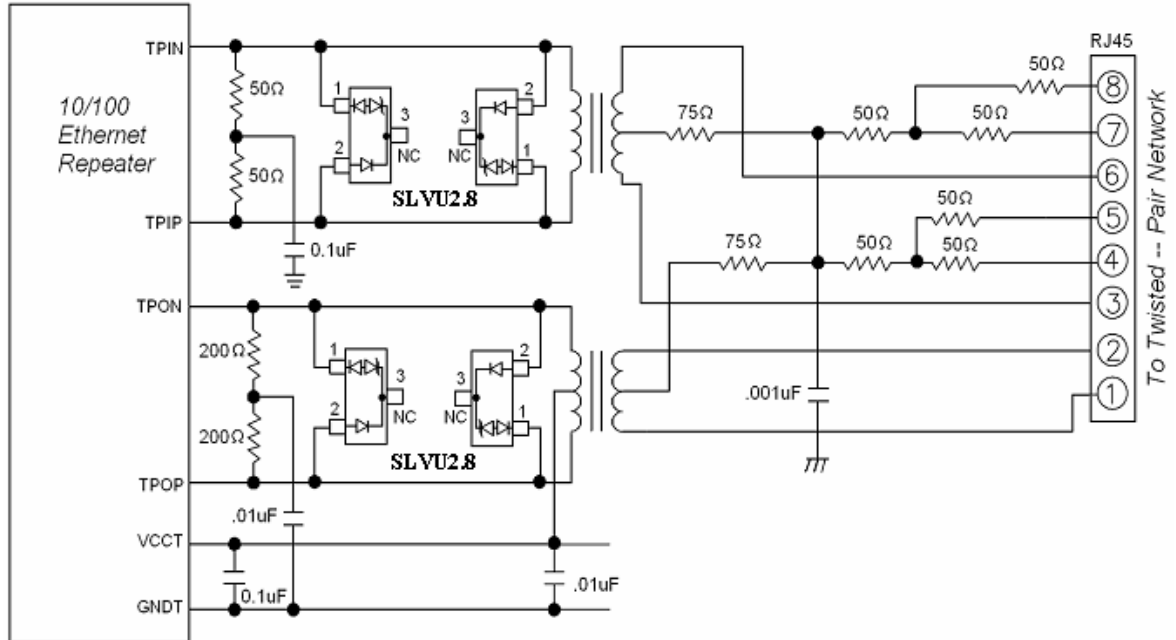
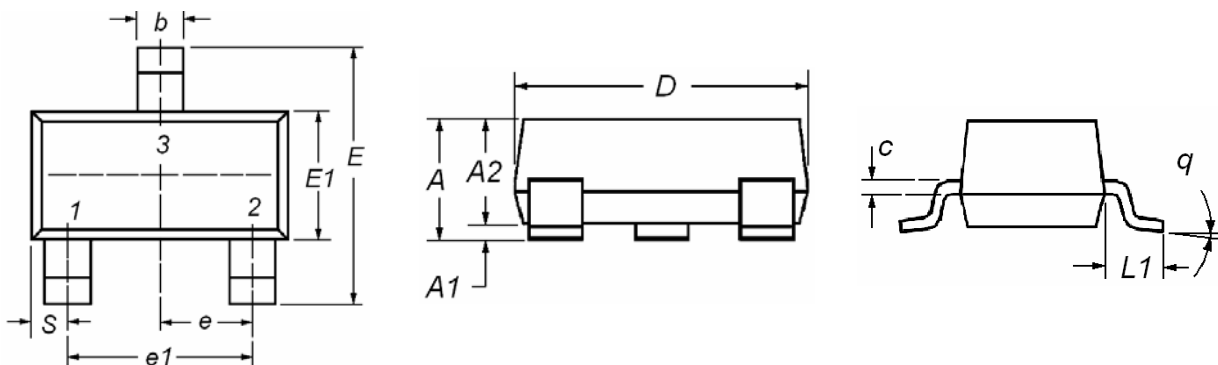

Fig13. 10/100 Ethernet "Enhanced" Lightning Protection Circuit

## SOT-23 MECHANICAL DATA

Dim	Millimeters		
	Min	TYP	Max
A	1.00		1.40
A1	0		0.10
A2	1.00		1.30
b	0.35		0.50
c	0.10		0.20
D	2.70	2.90	3.10
E	2.40		2.80
E1	1.40		1.60
e	0.85		1.15
e1		1.90	
L1	0.40	.	
q	0°		10°
S	0.45		0.55



© 2007 Printed in China – All rights reserved.

**SHENZHEN LANGTUO ELECTRONICS CO., LTD**

**Phone:** +86-755-82047892

**Fax:** +86-755-82048647

**Email:** sales@szlongtuo.com

**Website:** <http://www.szlongtuo.com>