

# **BL SURGE ABSORBER**

1. WORLD WIDE TECHNICAL PATENTS -----	P1
2. THE FUNCTIONS OF BLSA SERIES -----	P1
3. THE MAJOR CHARACTERISTICS OF BLSA -----	P2
4. BLSA PRODUCT FEATURES -----	P2
5. BASIC ELECTRICAL DIAGRAMS AND COMPARISON -----	P3
6. COMPARE I-V CHARACTERISTIC FOR DIFFERENT PRODUCTS --	P4
7. THE APPLICATIONS OF BLSA -----	P5
8. PRODUCT SPECIFICATION -----	P6
9. TEST METHODS AND RESULTS -----	P9
10. DIMENSIONS AND PACKING FORM -----	P10
11. UL SAFETY CERTIFICATIONS -----	P12

# ***BL SURGE ABSORBER***

## **1. WORLD WIDE TECHNICAL PATENTS**

BL mini Surge Absorber (BLSA) , invented and produced by Japan BL Kogyo INC. , is a series of high-tech electronic components and is fully protected by international patent law . Its patent register number in Japan is HEI 7-16632 ; in USA: 08/378,969 ; in Korean: 2021/1995 ; in China: 94202711.6 . BL Surge Absorber is an innovated high-tech mini-size device .

## **2. THE FUNCTIONS OF BLSA SERIES**

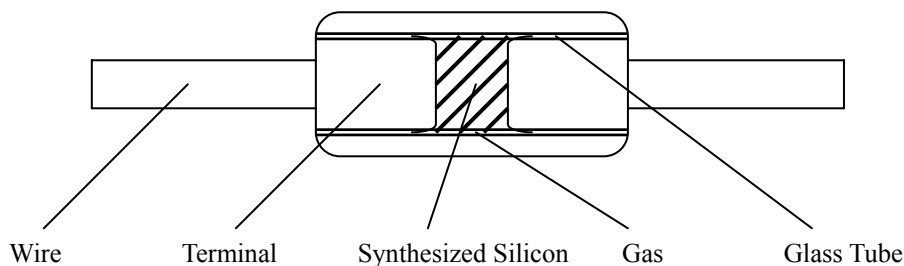

Fig. THE STRUCTURE OF BLSA

The surges such as those produced by high voltage transients, lightning, switching and noise spikes are the vital enemies of modern electronic equipment. Even the slightest interference of some common high voltage transients or noise spikes can cause errors in some semiconductor devices, or malfunction of computers, farther more result in the damage of the electronic equipment. Therefore, it is very necessary to eliminate and absorb the kinds of surge intrusion. Our BLSA is the best choice to carry on this protection function. It highly efficiently absorbs and eliminates those high voltage transients and protects electronic circuits from the damage caused by all kinds of surges and static. It improves the liability and prolongs the usage of electronic equipment, insures the quality of your products.

### **3. THE MAJOR CHARACTERISTICS OF BLSA**

BLSA is produced using silicon semiconductor as mediate inducing material and by our unique innovative processing technology based on the theory of high speed electronic reaction between a special type of super pure gas and silicon semiconductor. BLSA has its excellent clamping voltage characteristic and fast response time ( $>0.001\text{ps}$ ). It eliminates the discharge lag that is inductive of gap-type arrestors. It avoids the overheated damage happens in ZNR's type surge absorber (Zinc Oxide Nonlinear Resistor) due to their large electrostatic capacitance and leak current. BLSA also eliminates the variance in clamping voltage due to light effect that happens in some ionization gas tubes. BLSA's ideal bilateral and symmetrical V-I characteristic curve gives your circuits excellent clamping protection in either direction. Therefore, BLSA can be used both in AC and DC circuits to absorb surges by either positive or negative transients. BLSA can be used in circuits in place of back-to-back zener diodes for bi-directional protection.

### **4. BLSA PRODUCT FEATURES**

- Compared with other surge absorbers having similar functions , BLSA has the fast response speed , largest withstand current and voltage but smallest size
- Zero leaking current before clamping voltage
- All electrical characteristics are very stable even after long period of charge and discharge. There is no need for inspection and exchange periodically
- Super capability to withstand repeated lightning strikes
- Stable and very Small electrostatic capacitance ( $<0.8\text{pf}$ ) and great isolation ( $>100\text{M}\Omega$ )
- No pollution material
- Bilateral and symmetrical
- Completely insensitive to weather , temperature , humidity and lightness

BLSA thus provides a highly economical, reliable and unlimited duration way to protect against repeated quick rising edge surges and high voltage transients such as those produced by lightning, switching surges and noise spikes.

# 5. BASIC ELECTRICAL DIAGRAMS AND COMPARISON

Standard Impulse Current Waveform, 8/20 us

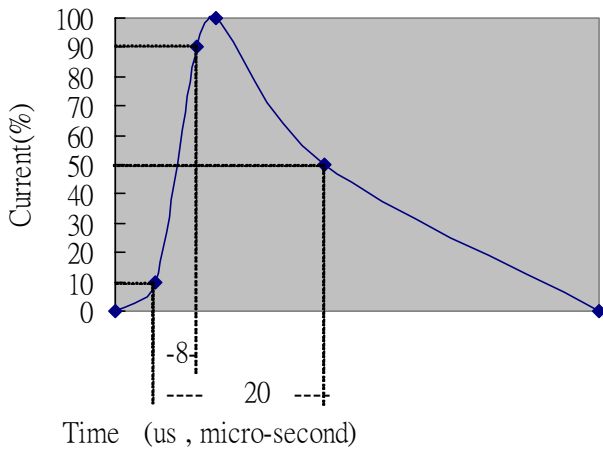

Maximum Peak Current Specification which specifies how much surge current, and surge absorber can endure is maximum peak current. That characteristics express a current value having standard wave form shown on the left .In case of different waveforms standard one, the specification shall determine referring to impulse life ratings.

All series of BLSA can handle very large Maximum Peak Current and have very small electrostatic capacitance. These features give BLSA the outstanding capability to compress lightning strikes, surges and static spikes.

10kv Fig-1.Lightning Original Waveform

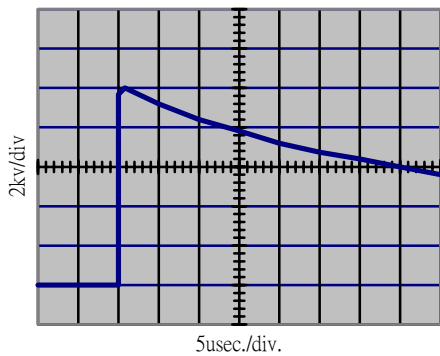

10 kv Fig-2.YA-242M Absorption Waveform

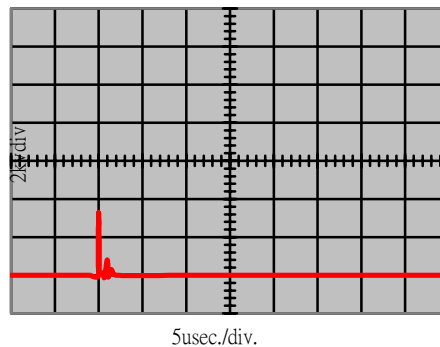

10kv Fig-3.Electrostatic Original Waveform

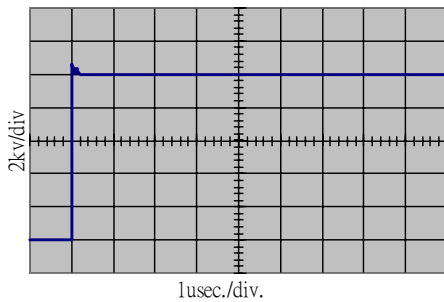

10kv Fig-4.YP-201N Absorption Waveform

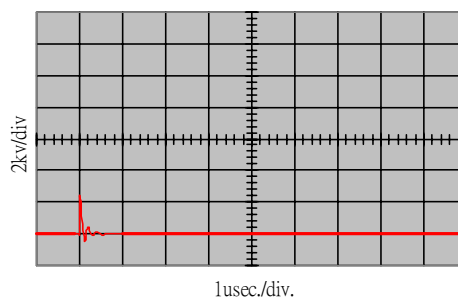

1kv Fig-5.Surge Original Waveform

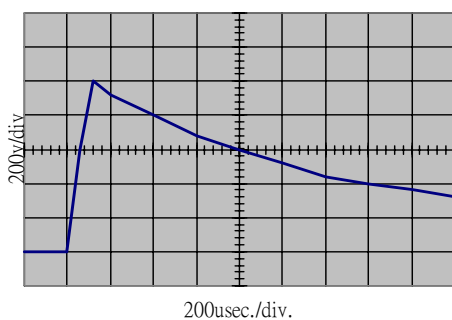

1kv Fig-6.YS-301L Absorption Waveform

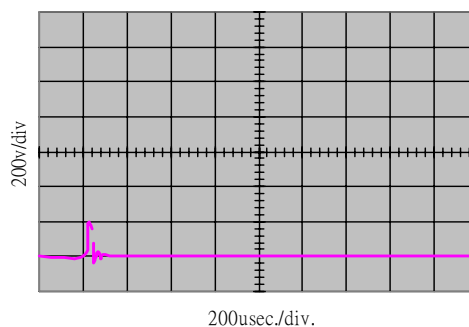
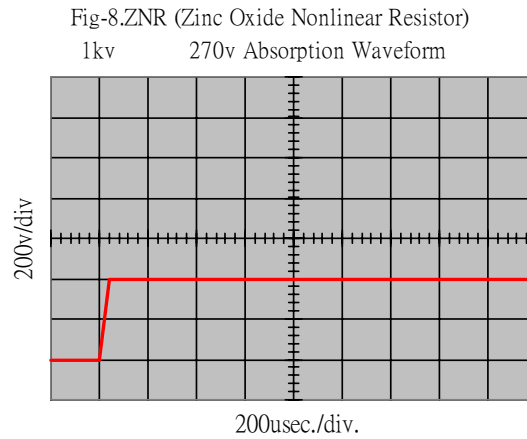
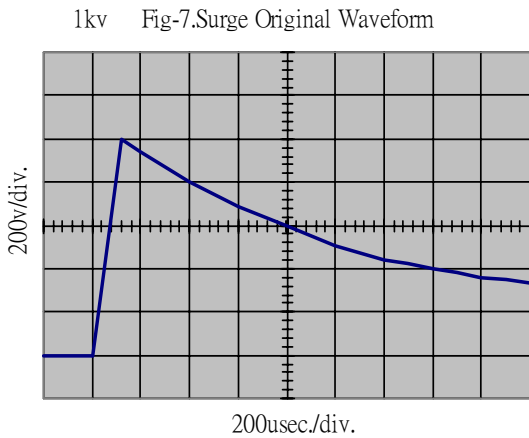

Fig-7 and Fig-8 show ZNR's characteristic when stricken by surge. Obvious, its capability to absorb surge and response time is affected by its bigger electrostatic capacitance and clamping point resistance.



## 6. COMPARE I-V CHARACTERISTIC FOR DIFFERENT PRODUCTS

Following is the comparison of I-V characteristic for different products with  $V_s=300v$  using Curve Tracer:

Fig-9.ZNR Transient/surge Absorber

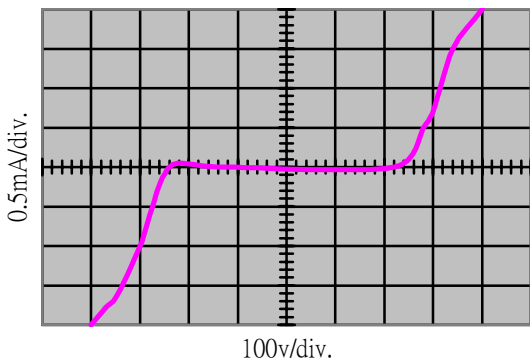

Fig-10.RSSA Surge Absorber

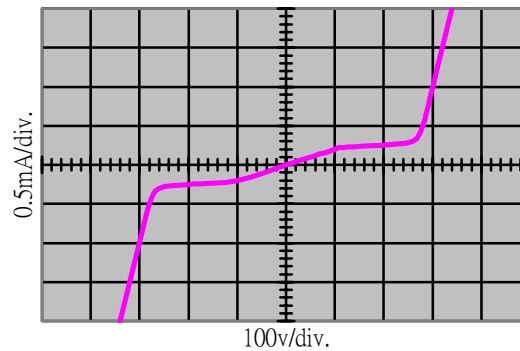
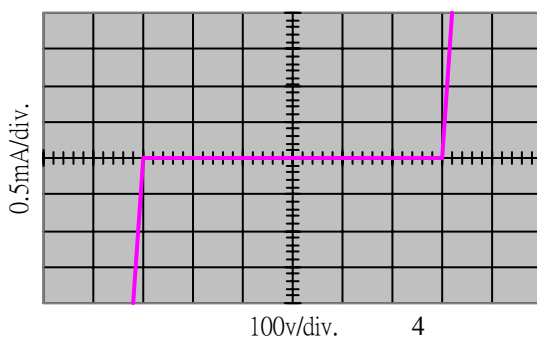

Fig-11, I-V curve clearly shows that BLSA has very small resistance at the bilateral clamping point. Compared with other surge absorber, BLSA has ideal high-speed transient response.

Fig-11.BL Mini Surge Absorber



## **7. THE APPLICATIONS OF BLSA**

For Power Supplies (YA or YS series)

- Standard power supplies requisite by US UL1449
- Highly reliable power supplies
- Three or two phases industrial or civic machinery equipment power
- Power supplies for IC or electronic circuits
- Surge compressor for switch and relay

For Data Communication Equipment (YA, YS or YP Series)

- Standard protection required by US UL497A and UL497B
- Programmable switch machine
- Telephone
- Fax
- Modem

Equipment with Antenna or Antenna/Signal Circuits including mobile equipment (YS or YP series)

- Standard protection required by US UL1414
- Satellite Antenna
- Amplifier
- Cassette
- Radio
- Alarm and sensor

Equipment where Anti-static is Required (YS or YP series)

- Display including TV
- Monitor
- Environment where dusty and flammable material are presented

All kinds of Medical equipment and devices (YA , YS or YP series)

## 8. PRODUCT SPECIFICATION

### YP Series:

Part Number	DC Spark-Over Voltage	Insulation Resistance	Electrostatic Capacitance 1KHZ-6Vmax	Surge current capacity	Surge Life
	Vs(V)	IR(OHM)/DC	C(pf)	8/20us	Test
YP-141 N	140 ( 98~ 182)	>100M/ 50V	< 0.8	500A	1500pf-0OHM 10KV >200Times
YP-201 M	200 (160~ 240)	>100M/100V			
YP-201 N	200 (140~ 260)				
YP-231 L	230 (196~ 265)				
YP-251 L	250 (212~ 287)				
YP-301 M	300 (240~ 360)				
YP-301 N	300 (210~ 390)				
YP-301 L	300 (255~ 345)				
YP-401 M	400 (320~ 480)	>100M/250V			
YP-451 M	450 (360~ 540 )				
YP-501 M	500 (400~ 600)				
YP-601 M	600 (480~ 720)				
YP-701 M	700 (560~ 840)				
YP-102 M	1000 (800~ 1200)	>100M/500V			
YP-102 N	1000 (700 ~1300)				
YP-152 M	1500 (1200~1800)				
YP-152 N	1500 (1050~1950)				

Dimension:

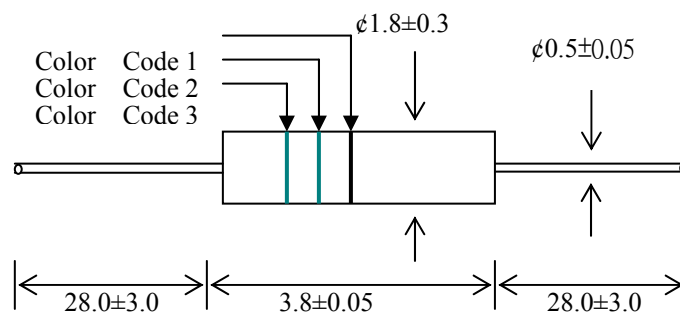

Color Code

Part Number	Color Code 1	Color Code 2	Color Code 3
141	Brown	Yellow	
201 M	Red		
201 N	Red	Red	
231 L	Red	Orange	
251	Red	Green	
301 L,M	Orange		
301 N	Orange	Orange	
401	Yellow		
451	Yellow	Green	
501	Green		
601	Blue		
701	Purple		
102 M	Black		
102 N	Black	Black	
152 M	Black	Green	
152 N	Black	Green	Green

## YS Series:

Part Number	DC Spark-Over Voltage Vs(V)	Insulation Resistance IR(OM)/DC	Electrostatic Capacitance 1KHZ-6Vmax C(pf)	Surge Current Capacity 8/20us	Surge Life Test
YS-201 M	200 (160~ 240)	>100M/100V	< 0.8	1000A	8/20usec 100A >300Times
YS-201 N	200 (140~ 260)				
YS-251 M	250 (200~300)				
YS-301 L	300 (255~ 345)				
YS-301 M	300 (240~ 360)				
YS-301 N	300 (210~ 390)				
YS-401 M	400 (320~ 480)				
YS-451 M	450 (360~ 540)	>100M/250V			
YS-501 M	500 (400~ 600)				
YS-551 M	550 (440~ 660)				
YS-601 M	600 (480~ 720)				
YS-701 M	700 (560~ 840)				
YS-102 M	1000 (800~ 1200)				
YS-122 M	1200 (960~ 1440)				
YS-152 M	1500 (1200~1800)				

Dimension:

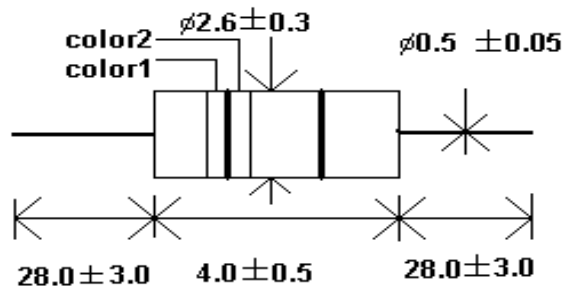

Color Code

Part Number	Color Code 1	Color Code 2
201 M	Red	
201 N	Red	Red
251	Red	Green
301 M,L	Orange	
301 N	Orange	Orange
401	Yellow	
451	Yellow	Green
501	Green	
551	Green	Green
601	Blue	
701	Purple	
102	Black	
122	Black	Red
152	Black	Green



## YA Series:

Part Number	DC Spark-Over Voltage	Insulation Resistance	Electrostatic Capacitance 1KHZ-6Vmax	Surge current capacity	Surge Life
	Vs(V)	IR(OM)/DC	C(pf)	8/20us	Test
YA-141 N	140 (98~182)	>100M/50V	< 0.8	3000A	8/20us 150A >300Times
YA-231 N	230 (161~299)	>100M/100V			
YA-251 N	250 (175~325)				
YA-301 L	300 (245~345)				
YA-351 M	350 (280~420)	>100M/250V			
YA-501 M	500 (400~600)				
YA-501 N	500 (350~650)				
YA-701 M	700 (560~840)				
YA-102 M	1000 (800~1200)				
YA-152 M	1500 (1200~1800)				
YA-202 M	2000 (1600~2400)				
YA-242 M	2400 (1920~2800)				
YA-302 M	3000 (2400~3600)				
YA-362 M	3600 (2880~4320)				
YA-402 M	4000 (3200~4800)				
YA-452 M	4500 (3600~5400)	>100M/1000V			
YA-502 M	5000 (4000~6000)				
YA-602 M	6000 (4800~7200)				

Dimension:

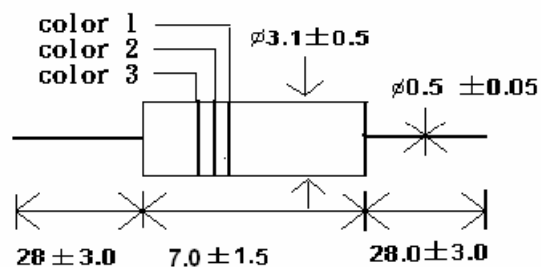

Color Code

Part Number	Color Code1	Color Code 2	Color Code 3
141	White	Yellow	
231	Red	Orange	
251	Red	Green	
301	Orange		
351	Orange	Green	
501	Green		
701	Purple		
102	Brown	Black	Red
152	Brown	Green	Red
202	Red	Black	Red
242	Red	Yellow	Red
302	Orange	Black	Red
362	Orange	Blue	Red
402	Yellow	Black	Red
452	Yellow	Green	Red
502	Green	Black	Red
602	Blue	Black	Red

## 9. TEST METHODS AND RESULTS

### *TEST METHODS and RESULTS*

ITEM	TEST METHOD	STANDARD
STATIC LIFE	10KV WITH 1500pf CONDENSER IS DISCHARGED THROUGH 2KΩ RESISTOR . 200 TIMES AT AN INTERVAL OF 10 SEC.	RATE-OF-CHANGE, WITHIN±30%. INSULATION RESISTANCE & CAPACITANCE, CONFORMED TO RATED SPEC.
COLD RESISTANCE	MEASUREMENT AFTER -40°C/1000 HRS & NORMAL TEMPERATURE/2 HRS.	FEATURES ARE CONFORMED TO RATED SPEC.
HEAT RESISTANCE	MEASUREMENT AFTER 125°C/1000 HRS & NORMAL TEMPERATURE/2 HRS.	
HUMIDITY RESISTANCE	MEASUREMENT AFTER HUMIDITY 90~95%(45 °C)/1000 HRS & NORMAL TEMP/2 HRS.	
TEMPERATURE CYCLE	10 TIMES REPETITION OF CYCLE -40°C/30MIN→ NORMAL , TEMP/2 MIN →125°C/30 MIN , MESUREMENT AFTER NORMAL TEMP/2 HRS.	
SOLDERABILITY	APPLY FLUX AND IMMERSE IN MOLTEM SOLDER 260±5°C FOR 3 SEC UP TO THE POINT OF 1.5MM FROM BODY . CHECK FOR SOLDER ADHESION.	LEAD WIRE IS EVENLY COVERED BY SOLDER.
SOLDER HEAT	MEASUREMENT AFTER LEAD WIRE IS DIPPED UP TO THE POINT OF 1.5MM FROM BODY INTO 265±5 °C SOLDER FOR 10 SEC.	CONFORMED TO RATED SPEC.
PULL STRENGTH	APPLY 0.5KG LOAD FOR 10 SEC.	LEAD SHALL NOT PULL OUT OR SNAP.
FLEXURAL STRENGTH	BEND LEAD WIRE AT THE POINT OF 2MM FROM BODY UNDER 0.25 LOAD AND BACK TO ITS ORIGINAL POINT. REPEAT 1 TIME.	

## 10. DIMENSIONS AND PACKING FORM

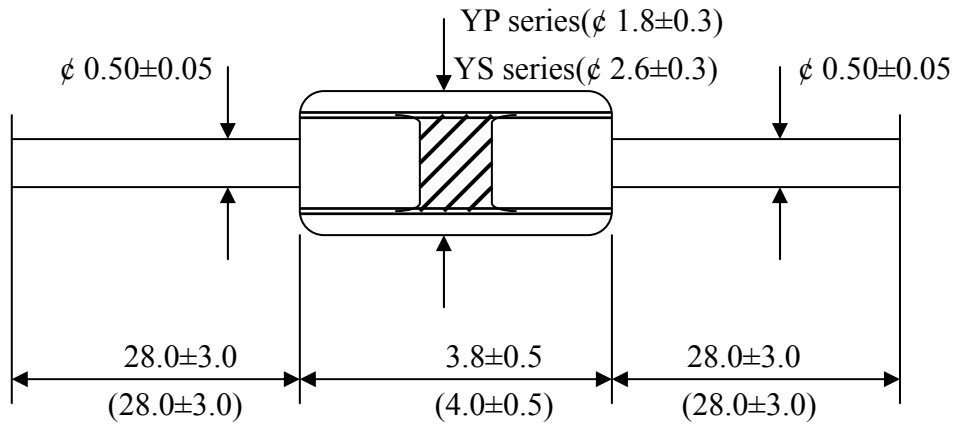

### Axial Taping

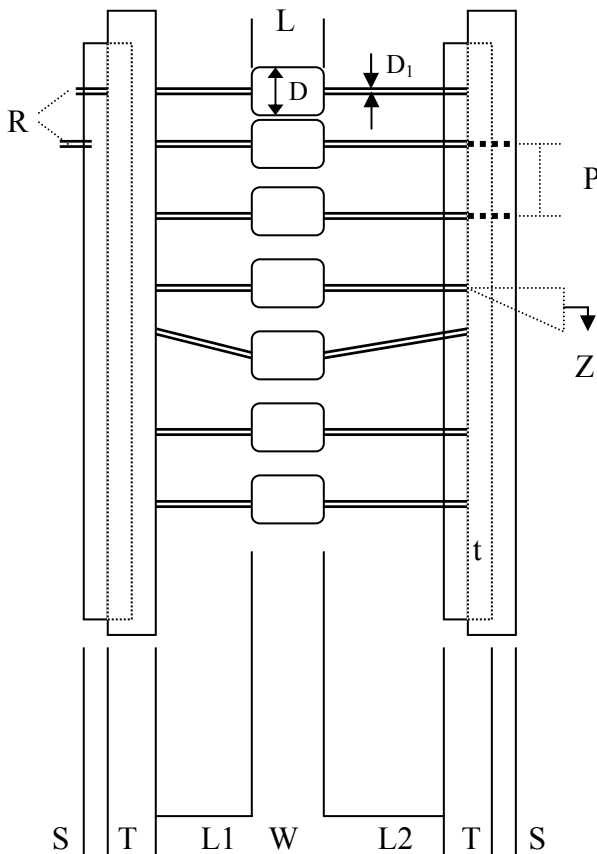

Symbol	Dimensions	
	YP series	YS series
W	$52 \pm 0.5$	
P	$5 \pm 0.5$	
L1-L2	1 max	
T	$6 \pm 1$	
Z	1.2 max	
R	Terminal must not project from the tape.	
t	3.2 min	
S	0.8 max	
D	$\phi 1.8\pm 0.3$	$\phi 2.6\pm 0.3$
D1	$\phi 0.50\pm 0.05$	$\phi 0.70\pm 0.05$
L	$3.8\pm 0.5$	$4.0\pm 0.5$

### ◆ PART NUMBER SYSTEM

B

B	Bulk
A	Axial
R	Radial

P

P	Pouch
F	Flat pack
T	Taping

◆PACKING FORM

STYLE	FORM	UNITY QUANTITY
B P	Bulk Packing	500 pcs/pouch
A F	Axial Taping	5000 pcs/box
R T	Radial Taping	2000 pcs/box

◆MARKING

Color code
Part Number
Red
2 0 1
Red+Green
2 5 1
Orange
3 0 1
Yellow
4 0 1

Flat pack

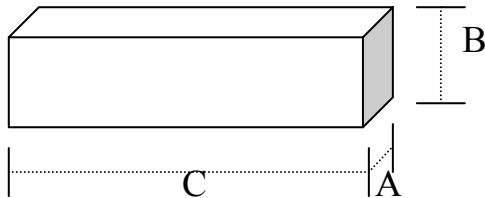

Unit : mm

A	68
B	45 - 125
C	250 - 610

Radial Taping (-RT)

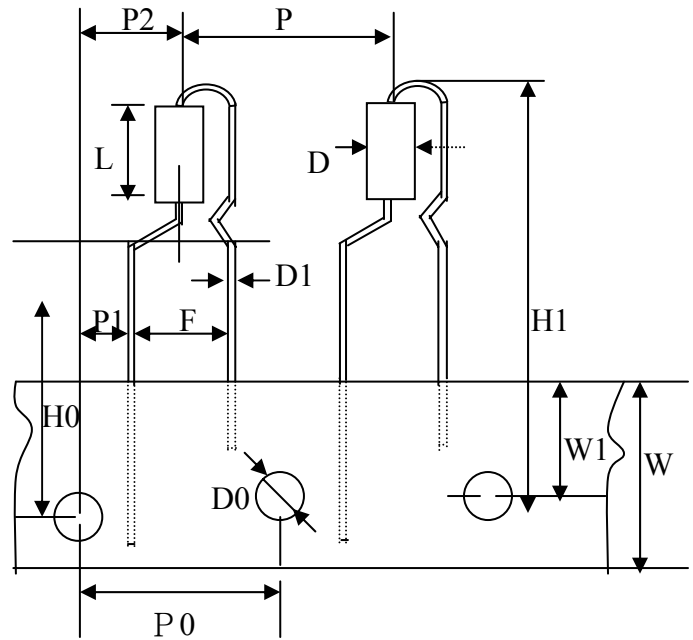

Symbol	Dimensions(mm)	
	Y P SERIES	Y S SERIES
P	12.7±1.0	
P0	12.7±0.3	
P1	3.85±0.5	
P2	6.35±1.3	
F	5.0±0.5	
W	1.8+1.0-0.5	
W1	9.0±0.5	
H0	1.6±0.5	
H1	32.2 (32.25MAX)	
D0	ϕ4.0±0.2	
D	ϕ1.8±0.3	ϕ2.6±0.3
D1	ϕ0.50±0.05	ϕ0.70±0.05
L	3.8±0.5	4.0±0.5

## 11. UL SAFETY CERTIFICATIONS

You can get our UL certifications numbers form following UL Online Certifications Directory URL.

<http://database.ul.com/cgi-bin/XYV/template/LISEXT/1FRAME/geosrch.html>

QVGQ2.E179423 - Isolated Loop Circuit Protectors – Component



Online Certifications Directory

### QVGQ2.E179423

### Isolated Loop Circuit Protectors - Component

#### Guide Information

**BL KOGYO INC** E179423

OTOTSU BLDG 101

2-5-6 SUMIYOSHI

KOTO-KU

TOKYO 135-0002, JAPAN

#### **Isolated loop circuit protector, Gas Tube,**

Series YS consisting of Models

YS-201M, -251M, -301M, -401M, -501M, -701M.

Series YP consisting of Models

YP-201M, -241L, -251M, -301M, -401M, -501M, -701M .

Series YP-M consisting of the following Models

YP-M-201M, YP-M-241M, YP-M-251M, YP-M-301M, YP-M-401M,  
YP-M-501M, YP-M-701M.

Series YS-S consisting of the following Models

YS-S-201M, YS-S-251M, YS-S-301M, YS-S-401M, YS-S-501M, YS-S-701M.

Marking: Company name or trademark *BL* and series designation.



## XUHT2.E238014

### Transient Voltage Surge Suppressors - Component

#### Guide Information

**BL KOGYO INC** E238014

OTOTSU BLDG 101

2-5-6 SUMIYOSHI

KOTO-KU

TOKYO 135-0002, JAPAN

**Transient voltage surge suppressors, gas tubes,**

Types

YA-301M, YA-501M, YA-272M, YA4-251M, YA4-272M, YA4-301M,  
YA4-501M, YS-301M, YS-501M, YS-272M.

Marking: Company name or trademark *BL* and catalog designation.